



Operators Manual

Pro Gear's Harmon-Herrington Operators manual to assist in identifying the parts for your Harmon-Herrington transfer case unit.

If you need any assistance identifying the correct transfer case unit for your truck and equipment, contact your Harmon-Herrington replacement part specialists at Pro Gear and Transmission.

Pro Gear Transmission has same day shipping and 1000's of products in stock and ready to ship internationally for your next project.

For parts or service contact the Harmon-Herrington specialists at Pro Gear & Transmission, Inc.

1 (877) 776-4600
(407) 872-1901
parts@eprogear.com

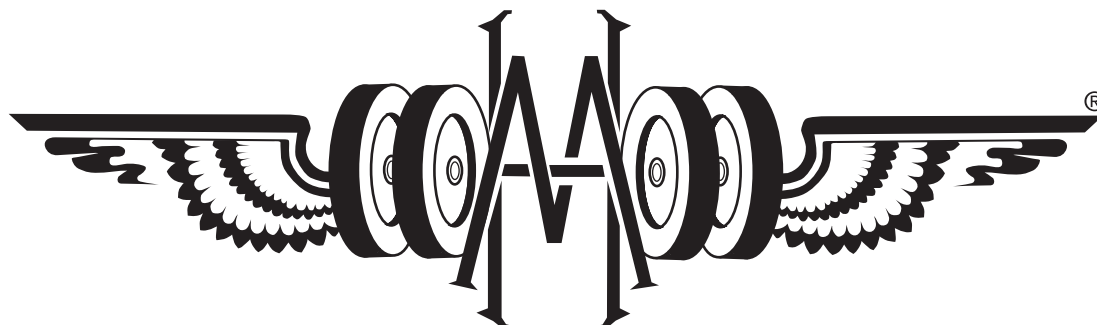

Marmon-Herrington

OPERATORS
MANUAL

REVISION: 8

DATE: 2014-02-26

DA02/14



TABLE OF CONTENTS

	Page
OPERATION INSTRUCTIONS	
Foreword.....	3
Transfer Cases.....	5
SERVICE INFORMATION	
Introduction.....	7
Lubrication.....	7
Maintenance Schedule - Axles.....	9
Maintenance Schedule - Transfer Cases.....	10
Lubrication Guide.....	10
Service and Maintenance.....	11
TRANSFER CASES	
Technical Data.....	13
Design.....	14
Shift Mechanism.....	20
Scheduled Maintenance Services.....	24
AXLES	
Front Axle.....	29
Adjustments.....	30
Troubleshooting.....	31
Lubrication Guide.....	32
Oil Levels of Wheel Hubs.....	33
Brake Lever Adjusting.....	35
Automatic Slack Adjuster.....	36
WARRANTY & SERVICE	
Ordering — Replacement Parts.....	37
Marmon-Herrington Warranty.....	38
Warranty Repair and Claim Procedure.....	39
Notes.....	40



FOREWORD

This manual has been prepared for owners and operators of vehicles equipped with Marmon-Herrington All-Wheel-Drive systems and components. For additional technical assistance, contact Marmon-Herrington Customer Service.

Please observe and follow all procedural and maintenance guidelines to ensure reliable operation and optimum service life. The Marmon-Herrington basic service schedule will integrate seamlessly with most preventative maintenance programs.

Marmon-Herrington shall not be liable for component failures or damages caused by operational abuse or neglect. Please review the Warranty Statement for a detailed explanation of coverage and claim reporting procedures.

We thank you for your investment in Marmon-Herrington equipment, and look forward to serving your needs in the tradition of engineering excellence.

GENERAL OPERATION STATEMENT

As close as engineers try to match gear ratios and tires for a given application, the reality is that there will always be some degree of ratio mismatch between front and rear axles. When a vehicle is operated on a hard, dry surface with the front axle engaged (AWD, 4X4, 6X6 modes), the tires are not able to slip and relieve the torsional forces being generated.

As such, Marmon-Herrington equipped vehicles are designed for “as needed” AWD operation only, in “off-road” or poor traction conditions. They are not intended to be driven in AWD mode on hard, dry surfaces.

Note: Seek expert advice when considering tire size or gear ratios changes.

SHIFTING OF AXLE OR TRANSFER CASE

Marmon-Herrington Axles and Transfer Cases use no clutching or synchronization devices, and therefore should only be shifted when the vehicle is at a complete stop. This applies to front axle engagement, high and low ranges, and locking differentials. The only exceptions are those vehicles equipped with Marmon-Herrington’s Safety-Shift system, which are calibrated to shift up to 5 mph.

“Shifting on the fly” generally results in two types of damage. The first is degradation of the engagement teeth due to relative rotation of the drive gears and shift collars. This type of damage can prevent the case from shifting normally, as the teeth become burred and cannot mesh.

The second condition occurs when a shift is actually completed at excessive speed. This results in extreme torque loading that is transmitted through the transfer case, drive shafts, and axles. The extent of possible damage increases proportionately with the vehicle speed.

SAFETY-SHIFT

In late 2003 Marmon-Herrington introduced Safe-T-Shift, an electronic management system developed to help prevent shift-on-the fly events. It consists of a microprocessor that receives speed information from a remote sensor in the transfer case. The system is calibrated to activate the shift solenoids at the first detection of motion, and then cancel control functions at 5 mph.

The actual completion of a shift still relies on the tooth alignment of the gear sets, and the vehicle may need to roll a few feet before the transfer case can shift. Because the system becomes active at first motion, and maintains air pressure thereafter, it is possible to accelerate rapidly to a speed greater than 5 mph before the tooth alignment occurs, thus allowing the teeth to grind against each other. In this case, the shift may occur while decelerating at a speed great enough to cause shock damage. For this reason, it is essential that the operator allow the vehicle to “walk” or idle forward until the shift is complete (indicated by the appropriate dash signal) before accelerating normally.



Note: Vehicles built after December 2007 are equipped with a 2nd generation Safe-T-Shift system which does not require motion to become active. It will activate the solenoids at a complete stop, and then cancel at 5 mph. This updated system simplifies the shift operation and allows for easier troubleshooting. Call Marmon-Herrington Customer Service to verify your vehicles system.

SHIFT PROCEDURE

1. With the vehicle at a complete stop, select the desired range or axle position.
2. Place the main transmission in gear.
3. Allow the vehicle to idle forward (or backwards) at walking speed until the shift is complete (as per the appropriate dash indicator).
4. Accelerate normally.

In case of a manual transmission, ease the clutch out in low gear, allowing the vehicle to “walk” until shift is complete (as per the appropriate dash indicator).

Some possible exclusions to the Safe-T-Shift program are those vehicles fitted with a transfer case mounted PTO, Freightliner factory installations, and any with Rockwell transfer cases.

SUMMARY

Before retreating from the subject of shifting, it must be reemphasized that no transfer case, PTO, axle differential, or power divider should ever be shifted while the vehicle is in motion. The engagement of these components is intended for off-road use only, in poor traction conditions.

TORQUE

“Torque Shock” or “Torque Loading” is a damaging mode of failure that is easily avoidable. It generally occurs in situations when a vehicle is operating in an area of low traction at high RPM with the wheels spinning. When the tires make abrupt contact with a tractable surface, a violent shock-load is transmitted through the drive train. This can result in damage to axles, drive shafts, transfer cases and transmissions.

Simply engaging the front axle and operating in low range at lower speeds will allow the vehicle to proceed without imparting undue stress on the drive train.



TRANSFER CASES

OPTIONAL POWER-TAKE-OFF (PTO)

On transfer cases with this option, the PTO is mounted on the rear of the case and driven by the input shaft. The PTO is a signal speed device that will operate at the same RPM as the main transmission in forward or reverse.

When mounting equipment to be driven by the PTO, it must be connected by way of a double universal joint type shaft to minimize thrust forces and shock loads to the PTO and transfer case, as well as the equipment being driven.

PTO ENGAGEMENT

The PTO should only be shifted when vehicle is at a complete stop. The PTO is engaged by way of an integrated shift cylinder using 95 - 115 PSI. Before engagement, the transfer case should be shifted to its neutral position. Automatic transmissions should be shifted to neutral and parking brakes set before engagement. In the case of a manual transmission, depress the clutch and allow for RPM drop. With the transfer case in neutral and PTO engaged, the main transmission may now be shifted to a drive gear for operation. Before disengaging the PTO, allow RPM to drop to idle, and shift main transmission to neutral.

If a task requirement calls for using the PTO while the vehicle is moving, the transfer case may be shifted to high or low range after PTO is engaged. Before using equipment while in motion, check with manufacturer to ensure that this is an approved operation.

“PD” T-CASES – MVG750PD, MVG1200PD, MVG2000PD

This series of transfer cases feature a proportioning differential between the front and rear outputs. This allows for the front drive axle to be constantly driven in a 30% front - 70% rear configuration.

In severe conditions where wheel slip is encountered, the differential may be manually locked, creating a solid link between front and rear output shafts. The differential lock should be disengaged as soon as traction is restored.

TOWING

In most cases the optimal procedure for towing is to remove the driveshaft from the axle that is being towed (example: front wheels lifted; rear wheels being towed). Towing a vehicle without removing the driveshaft from the towed axle will result in bearing and gear damage.

The only exceptions are transfer cases that are fitted with PTOs, as these units are plumbed for a switchable neutral position. In the case of a PTO style transfer case that can not be shifted into neutral due to air system failure, the driveshaft at the axle being towed must be removed.

TESTING

When performing diagnostics on a dynamometer or rolling test rack without the front axle engaged (front wheels stationary), limit test intervals to 2 minutes. While the front output pilot shaft employs a needle roller bearing to protect it from relative rotational heat damage, it should be allowed to cool for a few minutes between intervals.



FRONT AND REAR DRIVE AXLES

The Marmon-Herrington line of drive axles are rated from 8,000 - 23,000 pounds based on application and suspension components. The line includes front, rear and tandem drive axles in both single and double reduction configurations. A lighter series of front drive axle offers single reduction with optional free-wheel hubs.

Models with double reduction gear ratios utilize “wet” planetary hubs that require attention during scheduled preventative maintenance.

All Marmon-Herrington front drive axles have standard “double-cardan” steering joints which provide smoother steering and resist steering wheel “fight back” in full deflection turns. Latest joint designs are permanently lubed, and require no maintenance. Earlier units have plugs at each cap that can be removed to add non-pressurized grease.

Axles fitted with locking differentials should never be shifted while in motion as stated in the SHIFTING PROCEDURES section.

FREE WHEEL HUBS

On axles with free wheel hubs, the hubs must be completely engaged when the transfer case is in AWD mode and the front axle is being driven. In either mode (AWD or 2WD) both hubs must be either fully engaged or fully disengaged. Failure to observe these practices will result in component failure.

The hub is engaged by rotating the handle clockwise in accordance with its markings. On some axle models, a rubber cover will need to be removed to manipulate the hubs. Reinstall these protective covers after setting hub positions. If the hub selector is difficult to turn, rock the top of the tire back and forth by hand while twisting the selector handle.

Never operate the vehicle on hard, dry surfaces with the hubs engaged. This will result in gear train damage and tire wear.



INTRODUCTION

The efficiency and life of mechanical equipment is as dependent on proper lubrication as it is on proper engineering design. The importance of proper lubrication is increased because of greater gear tooth and bearing pressures and higher speeds in present day vehicles. For this reason we are vitally interested in promoting widespread usage of the best possible lubricants for our products.

It is advisable to consider the reputation of the refiner or vendor when selecting a lubricant. He is responsible for the quality and correct application of his product. A high quality lubricant incorrectly applied may greatly reduce the maximum service built into our product. Past experience has proven that a large portion of service problems can be traced to an improper lubricant or to an incorrect lubricant application.

Our purpose in compiling these specifications is to provide a guide to aid in the selection of a lubricant which will render the most satisfactory service.

We recommend a good quality gear lube for use in our axles and transfer cases. Suitable grades include 75w/90 thru 85w/140 and SAE90. Synthetics or mineral products are both appropriate.

LUBRICATION

A. LUBRICATION OF THE FRONT AXLE DIFFERENTIAL CARRIER

With new axles, the original lubricant should be drained at 1,000 miles (1,600 km) but no later than 3,000 miles (4,800 km). Change every 10,000 miles (16,000 km) or annually. Drain the lubricant initially used in the assembly while the assembly is still warm. Axles SHOULD NOT be flushed with any solvent such as kerosene. All new axles should be checked for correct oil level before being placed into service.

Fill axle housings to bottom of level hole (in carrier and/or housing) with specified lubricant with the vehicle on level ground.

The most satisfactory results will be obtained only when the lubricant is of the correct viscosity API GL-5 or MILL2105B. For general use, use SAE 85-140 EP Multi-Viscosity gear lube. Higher or lower viscosity may be required for extremely hot or cold weather.

VENTS

When filling wheel ends, take care not to over-fill the hubs. This results in lube being pumped up the vent tube, and out the vent. When this occurs, enough lube can be purged to cause heat damage to the planetary system.

If lube is observed leaking from the vent, the vent and it's tube must be removed and flushed with solvent. This cleans the inner walls of residual lube which can cause a capillary effect, resulting in continued siphoning. Ensure correct lube level after reinstalling tube and vent.

B. FRONT DRIVE STEERING AXLE WHEEL ENDS, UNIVERSAL JOINTS, BEARINGS, BUSHINGS AND KNUCKLE PINS

The frequency of lubricant changes depends upon individual operating conditions, speed and loads. Change whenever seals are replaced or when brakes are relined or at 10,000 miles (16,000 km) or annually.

Use a high grade Lithium chassis lubricant that conforms to NLGI-2EP requirements.

1. Check for looseness
2. Apply grease
3. Observe lube purging - except in the case of cardon joints
4. If the above is not successful, remove cup or joint and check old grease. If rusty, gritty or burned, replace.

NOTE: Axle shaft cardan joints are not serviceable with pressurized grease.

IMPORTANT: At rebuild time, before installing wheel bearings onto spindle, coat bearing journals with a film of grease to deter fretting corrosion. Apply 1/16" on spindle hub and knead into the bearings. Apply by hand, repack every 10,000 miles (16,000 km) or annually.

C. BRAKE LUBRICATION

A high temperature waterproof grease in a Number 1 NLGI Grade is recommended for lubricating the brake actuating system. It should be a smooth textured corrosion resistant grease free of fillers and abrasives. It should maintain a satisfactory softness under normal parking and storage temperatures so the brakes can be applied and released. Vehicles operating in extremely cold weather (below -40°) require a grease conforming to MIL-G-25013C.

WEDGE BRAKES AND CHAMBERS (ON-HIGHWAY AND OFF-HIGHWAY)



On-Highway – Change whenever seals are replaced or when brakes are relined.

Off-Highway – Change grease every 12 months (maximum), whenever seals are replaced and when brakes are relined. However, the change interval may be shorter than 12 months depending on the severity of service operations. This can be determined by initially scheduling an inspection of the internal parts and lubricant every 2 months until the first 12 month period has passed. At each inspection look for contaminated or hardened grease, or for the lack of grease.

CAM BRAKES (ON-HIGHWAY AND OFF-HIGHWAY)

On-Highway – Every 10,000 miles (16,000 km) or every 6 months for all components depending on severity of service.

Off-Highway – For all components, change grease every 4 months (maximum), whenever seals are replaced and brakes are relined. However, the change interval may be shorter than 4 months depending on the severity of service operation. This can be determined by initially scheduling an inspection of internal parts. At each inspection look for contaminated or hardened grease or for the lack of grease.

D. LUBRICATION OF TIE-ROD AND DRAG LINK

Use the same type of grease as for the wheel bearings.

E. LUBRICATION OF DRIVELINES

Off-Highway – The change interval will differ greatly and be determined largely on the type of vehicle or machinery being used, type of operation and severity of service. The lubricant change interval could be, for example, one (1) day maximum or three (3) months maximum. This can be determined by initially scheduling daily or weekly inspections of universal joint, shaft, and slip yoke parts. Check seals, bearings, splines, etc., and check condition of grease in the assemblies by purging with new grease. Look for contaminated or hardened grease or for the lack of grease. Also, check to make sure grease purges from all four (4) bearing and seal positions of the cross.

LUBRICATION PROCEDURES FOR UNIVERSAL JOINTS (DRIVE SHAFTS ONLY)

1. Check for looseness.
2. Apply grease.
3. Observe lube purging from all seals until new grease comes out.
4. If grease does not purge, manipulate the “U” joint until purging occurs.
5. If the above is not successful, remove cup or joint and check old grease. If rusty, gritty or burnt, replace the complete universal joint.

LUBRICATION PROCEDURES FOR SLIP YOKES AND SPLINES

1. Check for looseness or sideplay.
2. Apply grease until purging takes place at air hle in end of slip yoke.

NOTE: Axle shaft cardan joints are not serviceable with pressurized grease.

F. LUBRICATION OF TRANSFER CASE

Use same type and viscosity of gear lube as used in the differential carrier. Fill to the bottom of the fill hole. **DO NOT OVERFILL** as this may cause the case to run hot, or cause lubricant to be pumped out of the vent.

Transfer Case may be mounted at various approved angles by the vehicle manufacturer and normally should be filled to the bottom of the tapped hole. Capacities will vary depending upon the angle of mounting.

Lubricant should be drained at 1,000 miles (1,600 km) but no later than 3,000 miles (4,800 km). Change every 10,000 miles (16,000 km) or annually. Drain the lubricant initially used in the assembly while the assembly is still warm. Transfer Case **SHOULD NOT** be flushed with any solvent such as kerosene.

G. MAGNETIC DRAIN PLUGS

Any drive axle or transfer case while it is working, generates wear particles at a fairly steady rate. These wear particles are very fine but hard. If these hard wear particles are allowed to circulate in the lubricant, the anti-friction bearings will wear at a faster rate than they would if the hard wear particles were removed as they are generated.



MAINTENANCE SCHEDULE – AXLES

1,000 Miles

1. Change lube in differential and hubs no later than 3,000 miles.

5,000 Miles

1. Re-torque wheel nuts after 100 and 500 miles, then every 5,000 miles thereafter.
2. Clean vent and vent tubes.
3. Check operation of differential lock control pressure switch.

10,000 Miles

1. Change lube in differential and hubs.
2. Lube brake cam bushings and brake levers.

15,000 Miles

1. Check shoe clearance and brake lining wear.

30,000 Miles

1. Check brake shoes, drums and parts for wear.
2. Check and re-torque mounting bolts.
3. Lube brake shoe rollers.

60,000 Miles

1. Check and adjust wheel bearings.

Note: Change lube annually if vehicle operates less than prescribed mileage periods.



MAINTENANCE SCHEDULE – TRANSFER CASES

1,000 Miles

Change Lube.

10,000 Miles

Change lube and check vent every 10,000 miles.

Note: Change lube annually if vehicle operates less than prescribed mileage periods.

Viscosity is dependant on ambient regional temperature:

Tropic Zone: SAE 85W/140

Normal Zone: SAE 85W/90 - SAE 85W/140 – SAE 90

Frigid Zone: SAE 80W – SAE 75W/140 – SAE 75W – 90

LUBRICATION GUIDE

Acceptable Grades (-26C to 38C / -14.8F to 100F)

BP hypergear EP

Castrol EXP, Dynadriver 80W/90

ELF Tranself TYPE B

ESSO Gear Oil GX 80W/90

GX-D85W/90

MOBIL Mobilube HD

Shell Spirax HD

Total Transmission TM 85W/90

Lithium Based Lube (Grease)

Specification: NLGI-2EP

Acceptable Grades:

MOL LZS-2 EP

AGIP GR MU/EP2

SHELL Alvania EP2

Use AGIP AUTOL TOP 2000 for brake rollers.

Lubrication and Inspection Points - Axles

1. Oil level plug (hubs)
2. Oil fill and drain plugs (hubs)
3. Vent and vent tube (wheel ends)
4. Oil level and drain plugs (housing)
5. Differential vent (housing)
6. Lube fittings at brake arms
7. Slack adjuster



SERVICE AND MAINTENANCE

HIGH PRESSURE CLEANING

When using high pressure cleaning equipment, it should be applied in such a way that:

- the water jet does not penetrate the shaft oil seals
- the cleaning water does not enter through the breather orifices

PRESERVATION FOR STORAGE

The transfer case should be stored inside a room with low air circulation with maximum relative humidity of 60% and a temperature between 15 and 20 C.

We recommend to issue storage cards to keep record of the preservation details and dates.

Our transfer cases were filled for the test run in our factory. The remaining quantity of oil protects the unit temporarily against corrosion.

If intending to store the unit for more than 4 months, carry out the following preservation procedure.

1. Remove breather and seal bore by means of suitable plug.
2. Fill gear oil according to instruction chapter (“oil change and maintenance”).
3. Rotate transfer cases in such a way that all interior surfaces are coated with oil.
4. Turn shafts and at the same time shift twice every position of all shifting cylinders (see chapter “handling”).

When storage conditions are favorable (less than 60% humidity) repeat procedure points 3 - 5 every 6 months.

When conditions are extreme (arctic or tropical, high humidity, high variation of temperature, storage location is near to sea) repeat procedure points 3 - 5 every four months.

CAUTION: Before putting the transfer case into use the breather must be installed!



DESCRIPTION

TECHNICAL DATA

TRANSFER CASE TYPE	INPUT TORQUE (lb-ft)	INPUT SPEED MAX. (r.p.m.)	WEIGHT APPROX. (w/o oil, PTO) lb	RATIO	
				on-road	off-road
MVG 750 w/o diff.	7,400	3,500	254	1.00	2.00
MVG 750 w. diff.	7,400	3,500	275	1.00	2.00
MVG 754 w/o diff.	7,400	3,500	341	1.00	2.00
MVG 1200 w/o diff.	11,000	3,000	484	1.00	1.75
MVG 1200 w. diff.	10,000	3,000	506	1.00	1.75
MVG 1600/300 w/o diff.	15,000	2,800	671	0.89	1.54
MVG 1600/396 w/o diff.	15,000	2,800	638	0.89	1.54
MVG 1600/300 w. diff.	15,000	2,800	693	0.89	1.54
MVG 1600-396 w. diff.	15,000	2,800	660	0.89	1.54
MVG 2000/300 w/o diff.	18,500	2,800	737	0.89	1.54
MVG 2000/396 w/o diff.	18,500	2,800	726	0.89	1.54
MVG 2000/300 w. diff.	18,500	2,800	781	0.89	1.54
MVG 2000/396 w. diff.	18,500	2,800	770	0.89	1.54
T30-420	11,500	3,500	480	1.09	2.47
T60	13,500	3,100	517	0.98	2.48



DESIGN

MVG 750 without differential

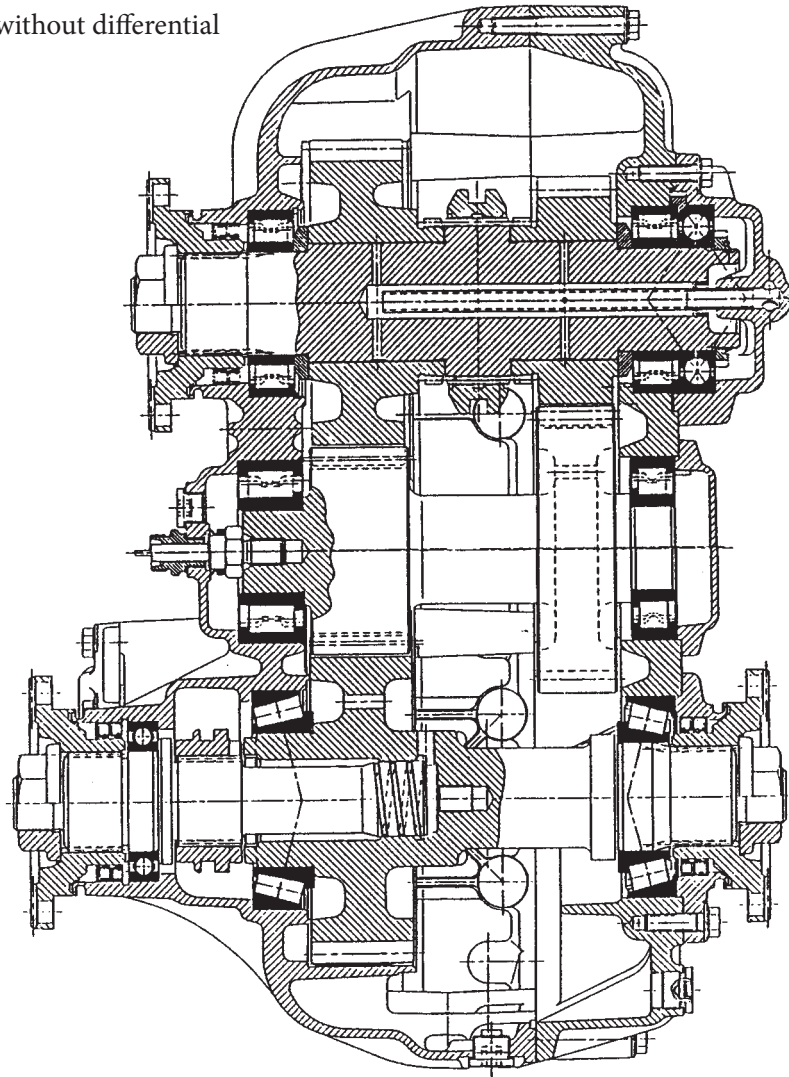

The MVG 750 without differential 3-shaft design, 2-speed transfer case with clockwise input drive direction.

Housing: two-pieces aluminum

Bearing application: Input shaft - cylinder roller and 4-point-bearing
Intermediate shaft - cylinder roller bearings
Output shaft - tapered roller bearings
Front output shaft - roller bearing, slide bearing

Lubrication: splash lubrication or splash / force feed lubrication with pump at input shaft

Shifting: pneumatic - 2 or 3 positions

Front drive: pneumatic operation

Options: pneumatic operation PTO; synchronisation; ADM



DESIGN

MVG 750 with differential

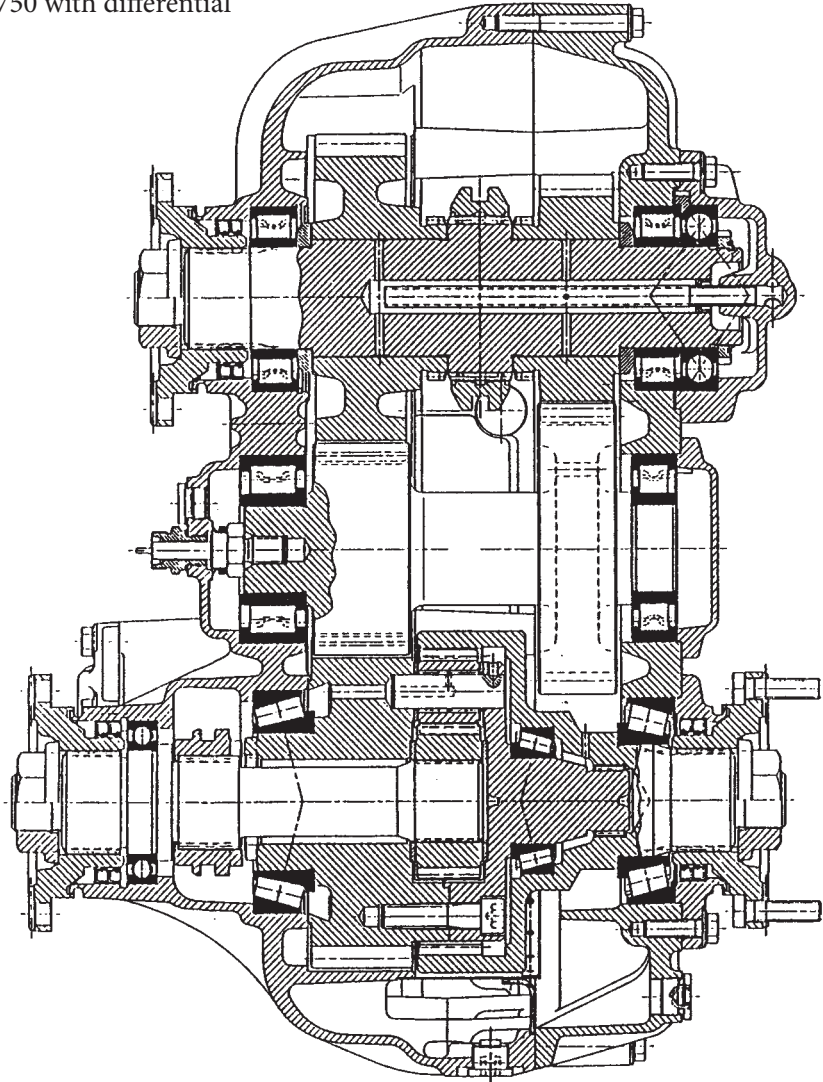

The MVG 750 with differential 3-shaft design, 2-speed transfer case with clockwise input drive direction.

The spur gear planetary differential has a torque distribution ratio between front and rear axle of (1 : 2.00)

Housing: two-pieces aluminum

Bearing application:	Input shaft	- cylinder roller and 4-point-bearing
	Intermediate shaft	- cylinder roller bearings
	Output shaft and differential	- tapered roller bearings and needle bearing
	Front output shaft	- roller bearing, slide bearing

Lubrication: splash lubrication or splash / force feed lubrication with pump at input shaft

Shifting: pneumatic - 2 or 3 positions

Front drive: pneumatic, differential pneumatically lockable

Options: pneumatic operation PTO; synchronisation; ADM



DESIGN

MVG 754 without differential

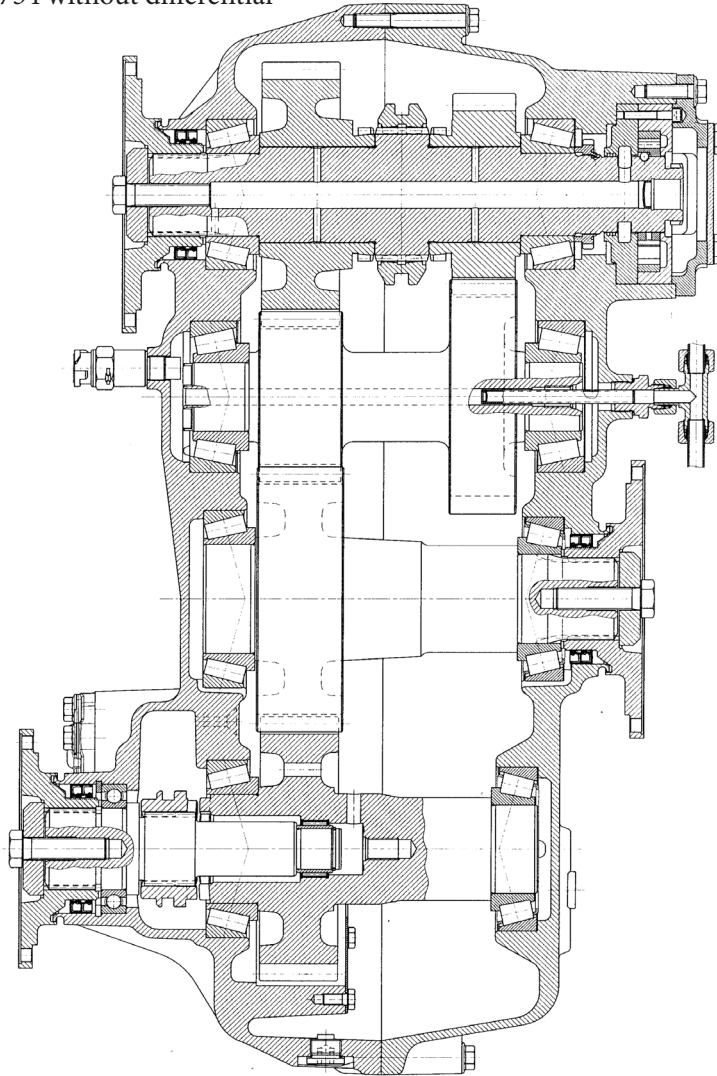

The MVG 754 without differential 4-shaft design, 2-speed transfer case with clockwise input drive direction.

Housing: two-pieces aluminum

Bearing application:	Input shaft	- tapered roller and 4-point-bearing
	Intermediate shaft	- tapered roller bearings
	Rear Output shaft	- tapered roller bearings
	Front output shaft	- tapered roller bearing, slide bearing

Lubrication: splash / force feed lubrication with pump at input shaft

Shifting: pneumatic - 2 or 3 positions

Front drive: pneumatic operation

Options: pneumatic operation PTO; synchronisation; ADM



DESIGN

MVG 1200 without differential

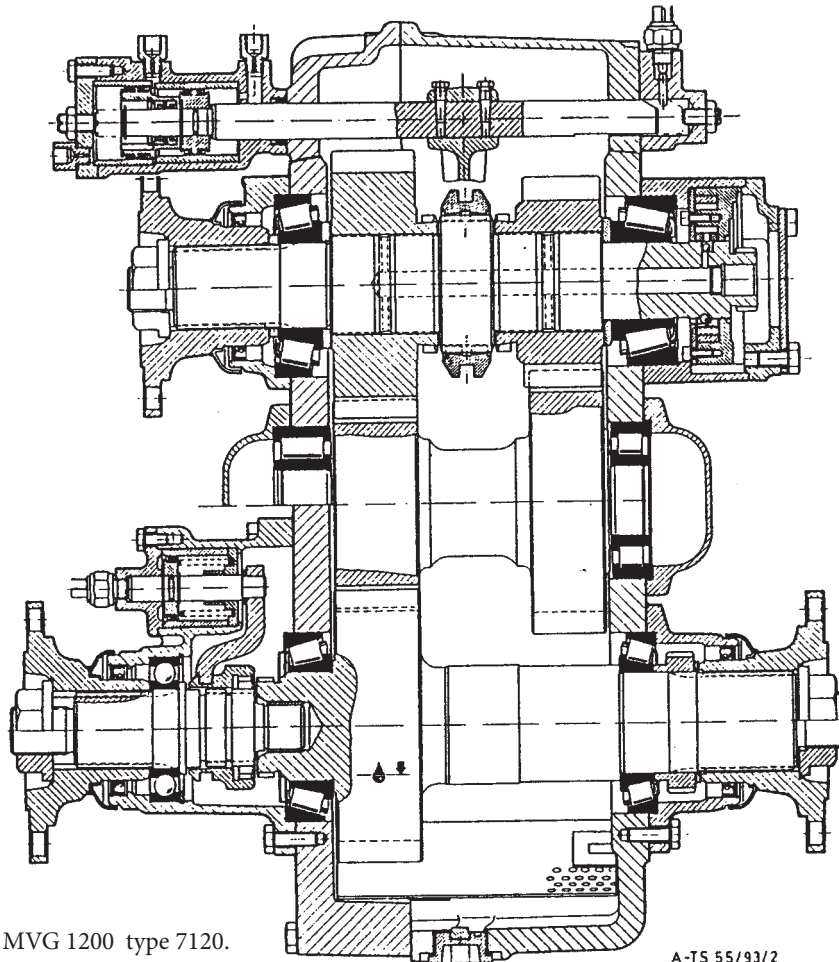

Cross section MVG 1200 type 7120.

A-TS 55/93/2

The MVG 1200 without differential 3-shaft design, 2-speed transfer case with clockwise input drive direction.

Housing: two-parts

Bearing application: Input shaft - taper roller bearings
Intermediate shaft - cylinder roller bearings
Output shaft - tapered roller bearings
Front output shaft - roller bearing, slide bearing

Lubrication: splash lubrication or splash / force feed lubrication with pump at input shaft

Shifting: mechanical - 3 positions
pneumatic - 2 or 3 positions

Front drive: pneumatic operation

Options: pneumatic operation PTO; without front drive; rear engine drive version; version towable without disconnecting the drive shaft in neutral position; external oil cooler connection; electronic speedometer connection; input drive direction counter-clockwise; synchronisation; ADM



DESIGN

MVG 1200 with differential

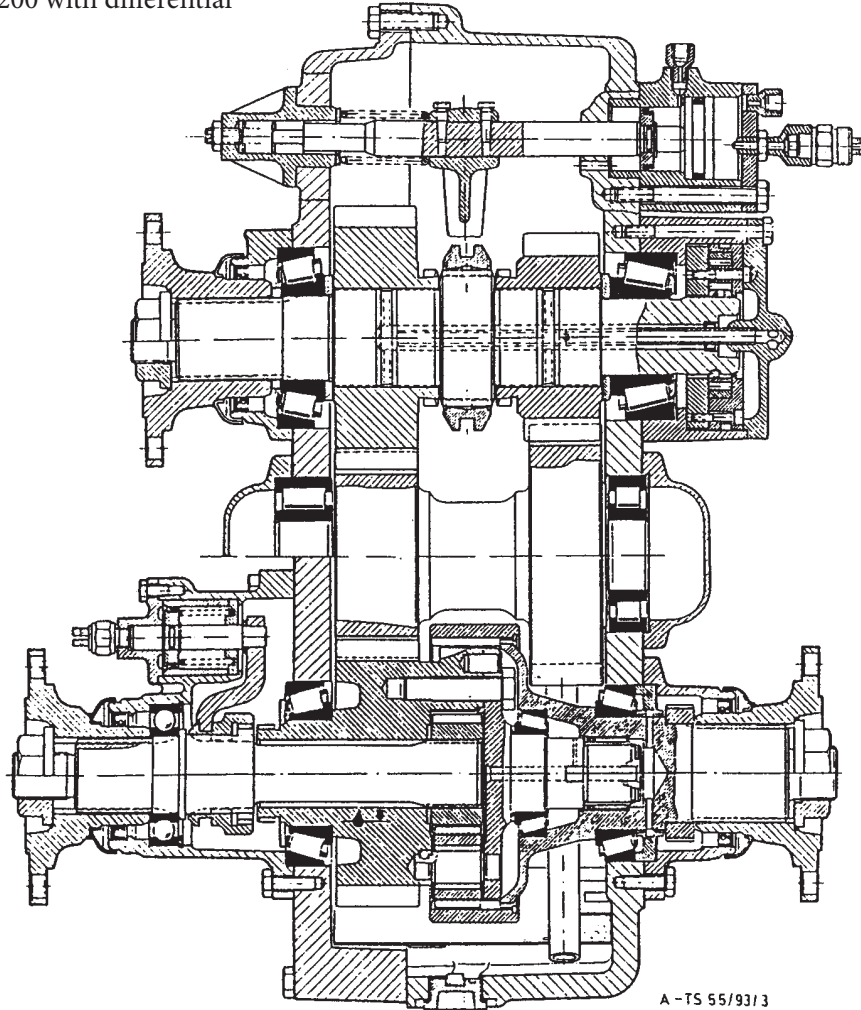

Cross section MVG 1200 type 7124.

The MVG 1200 with differential 3-shaft design, 2-speed transfer case with clockwise input drive direction (view to input flange).

Housing: two-parts

Bearing application:	Input shaft	- taper roller bearings
	Intermediate shaft	- cylinder roller bearings
	Output shaft and differential	- tapered roller bearings and needle bearing
	Front output shaft	- roller bearing, slide bearing

Lubrication: splash lubrication or splash / force feed lubrication with pump at input shaft

Shifting: mechanical - 3 positions
pneumatic - 2 or 3 positions

Front drive: pneumatically, differential pneumatically lockable

Options: pneumatic operation PTO; rear engine drive version; pump fitting at front and rear drive; version towable without disconnecting the drive shaft in neutral position; external oil cooler connection; electronic speedometer connection; input drive direction counter-clockwise; synchronisation; ADM



DESIGN

MVG 1600

without differential

MVG 2000

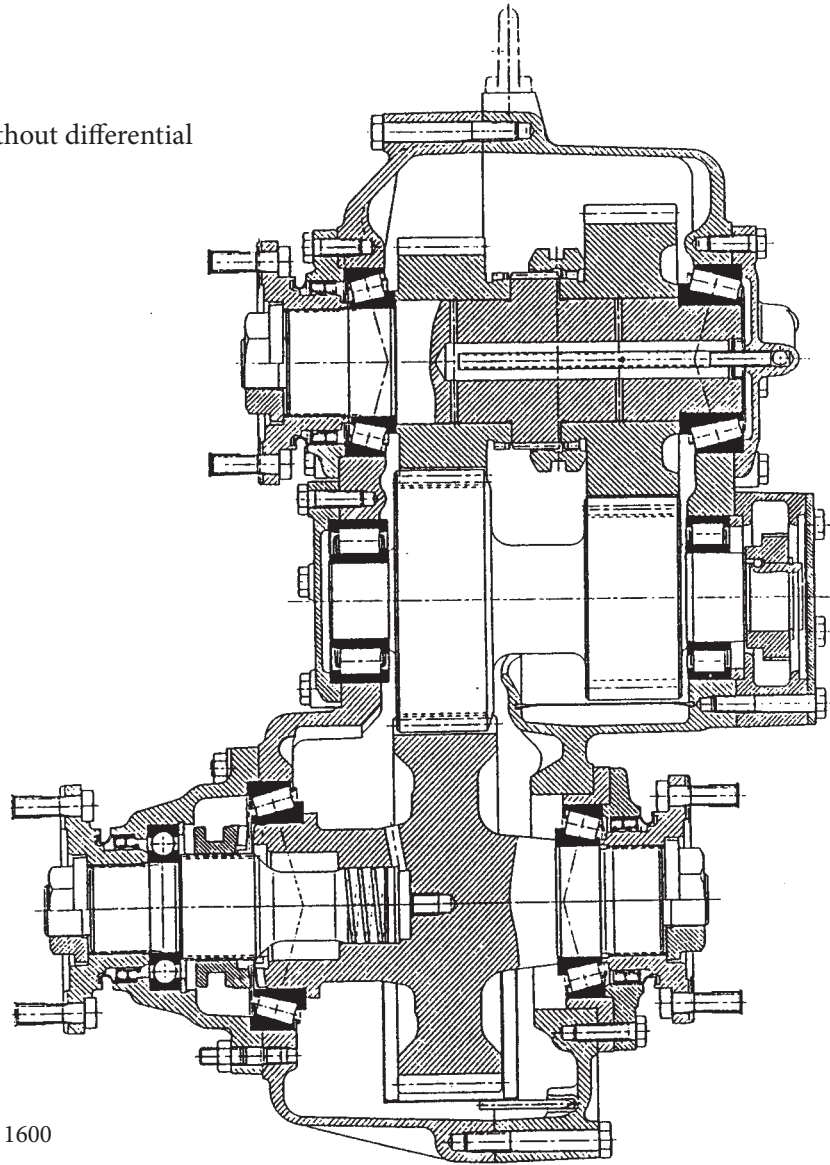

Cross section MVG 1600

The MVG 1600 / MVG 2000 without differential is a 3-shaft design, 2-speed transfer case with clockwise input drive direction (view to input flange).

Housing: two-parts

Bearing application:	Input shaft	- taper roller bearings
	Intermediate shaft	- cylinder roller bearings
	Output shaft	- tapered roller bearings
	Front output shaft	- roller bearing, slide bearing

Lubrication: splash lubrication or splash / force feed lubrication with pump at input shaft for the executions with PTO and for external cooling system, rear engine drive version and version with mechanical shifting

Shifting: mechanical - 3 positions
pneumatic - 2 or 3 positions

Options: pneumatic operation PTO; without front drive; rear engine drive version; pump fitting at front and rear side; external oil cooler connection; electronic speedometer connection; input drive direction counter-clockwise; synchronisation; ADM



DESIGN

MVG 1600

with differential

MVG 2000

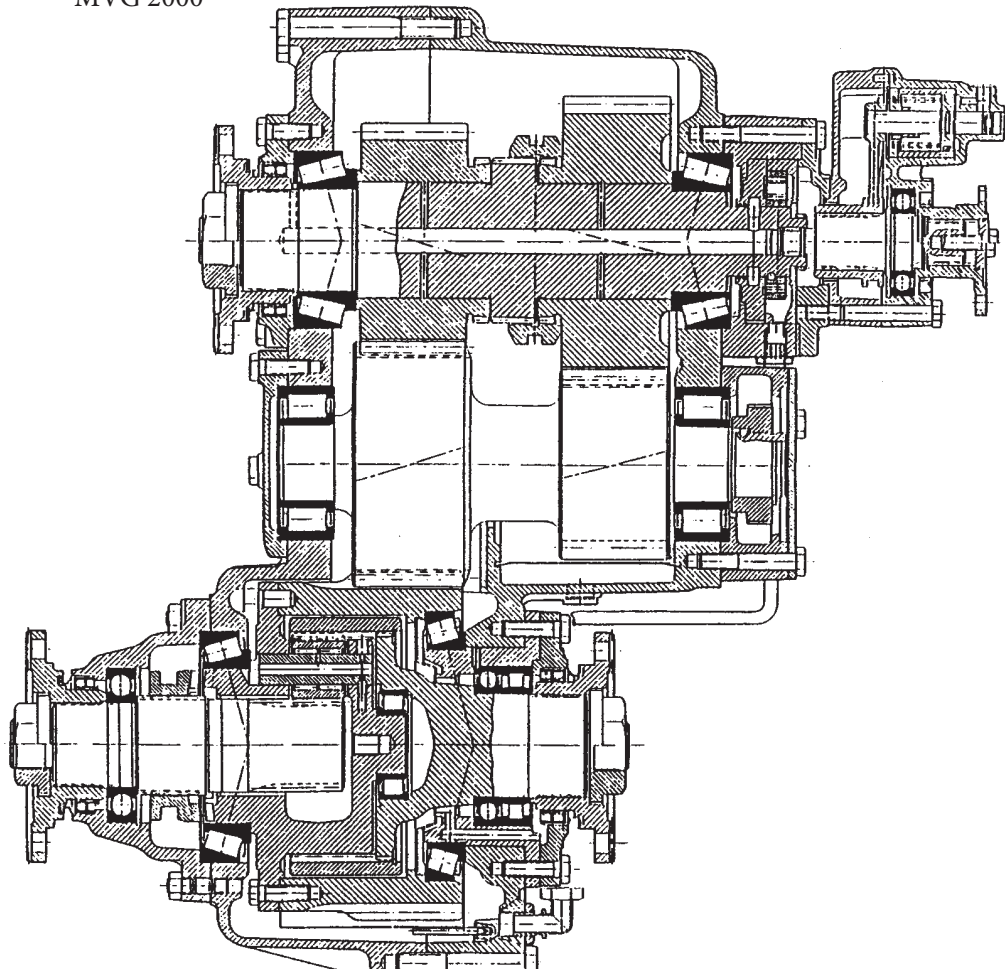

Cross section MVG 2000

The MVG 1600 / MVG 2000 with differential 3-shaft design, 2-speed transfer case with clockwise input drive direction (view to input flange).

Housing: two-parts

Bearing application:	Input shaft	- taper roller bearings
	Intermediate shaft	- cylinder roller bearings
	Output shaft and differential	- tapered roller bearings and needle bearing
	Front output shaft	- roller bearing, slide bearing
	Rear drive	- cylinder roller bearing, 4-point bearing

Lubrication: splash lubrication or splash / force feed lubrication with pump on input shaft for the executions with PTO and for external oil cooling system

Shifting: mechanical - 3 positions
pneumatic - 2 or 3 positions

Front drive: pneumatic, differential pneumatically lockable

Options: pneumatic operation PTO; rear engine drive version; pump fitting at front and rear side; external oil cooler connection; electronic speedometer connection; input drive direction counter-clockwise; synchronisation; ADM



DESCRIPTION - Shift mechanism

Pneumatic Shifting:

High and Low
3 positions, without return spring

MVG 750

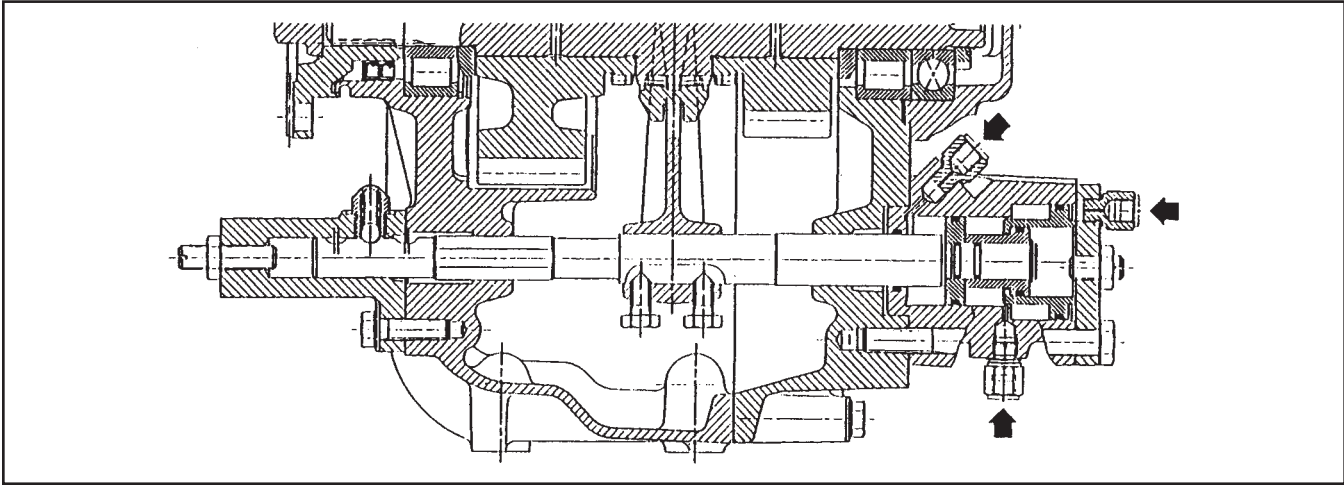

Pneumatic Shifting:

High and Low
3 positions, without return spring
3rd position (C) neutral used only in PTO applications

MVG 754

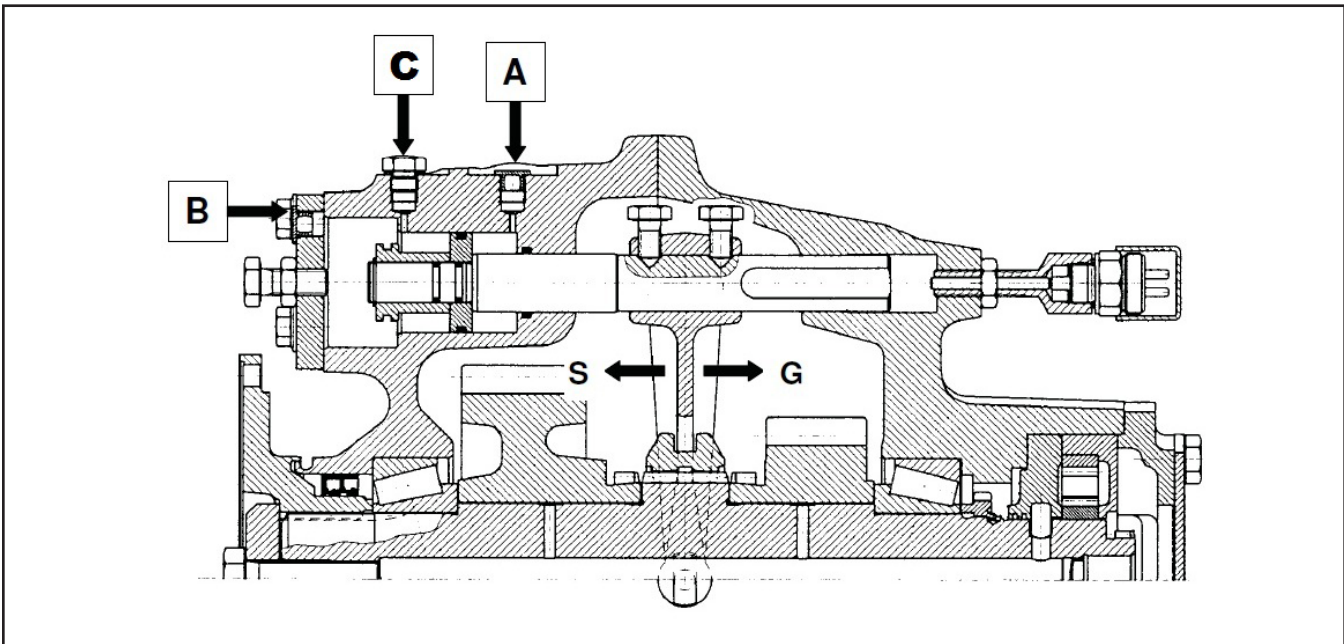

DESCRIPTION - Shift mechanism

Pneumatic Shifting:

High and Low

3 positions, without return spring

3rd position (C) neutral used only in PTO applications

MVG 1200

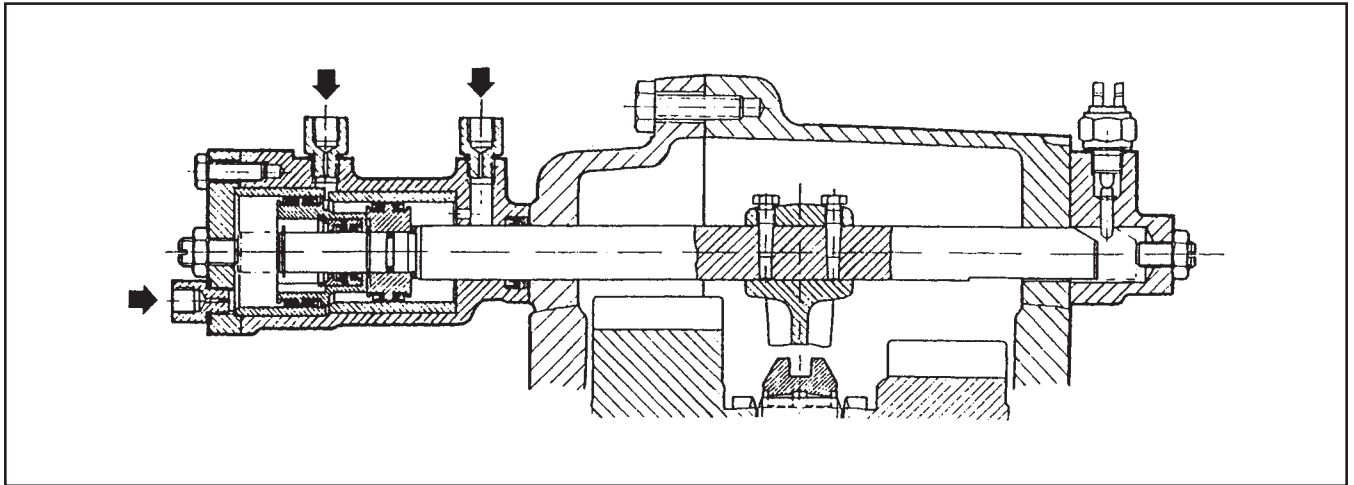

Pneumatic Shifting:

High and Low

2/3 positions, with return spring

MVG 1600 / MVG 2000

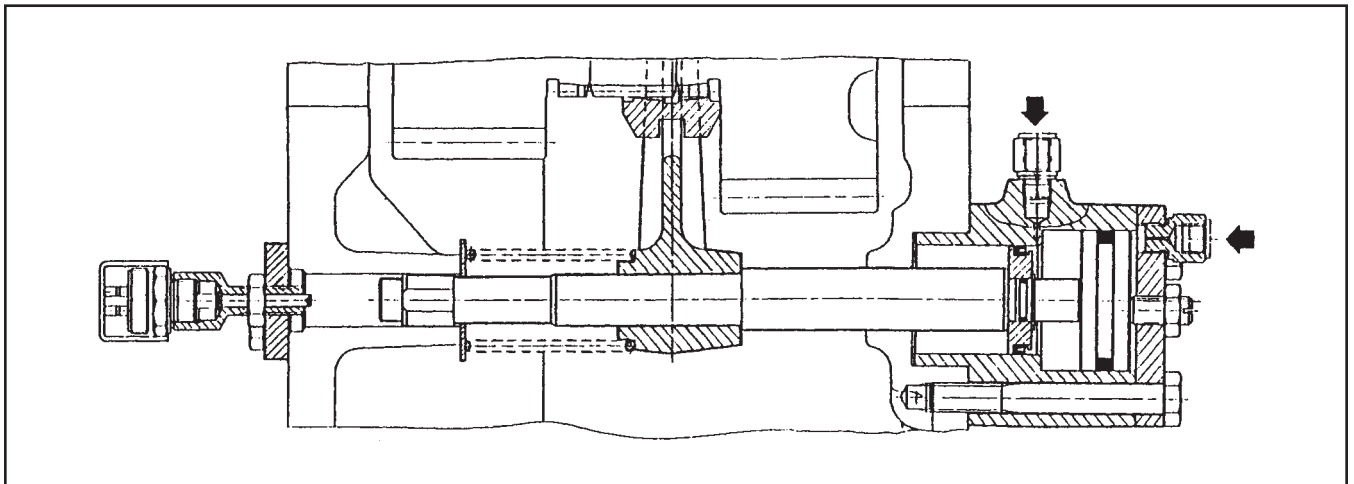

Attention:

For "pneumatic shifting with spring" we want to point out that in case of an air pressure loss the gear changes due to the spring pressure on MVG 1600 and MVG 2000 from low to high.



DESCRIPTION - Shift mechanism

Pneumatic Shifting:

High and Low

3 positions with detent, without return spring

MVG 1600 / MVG 2000

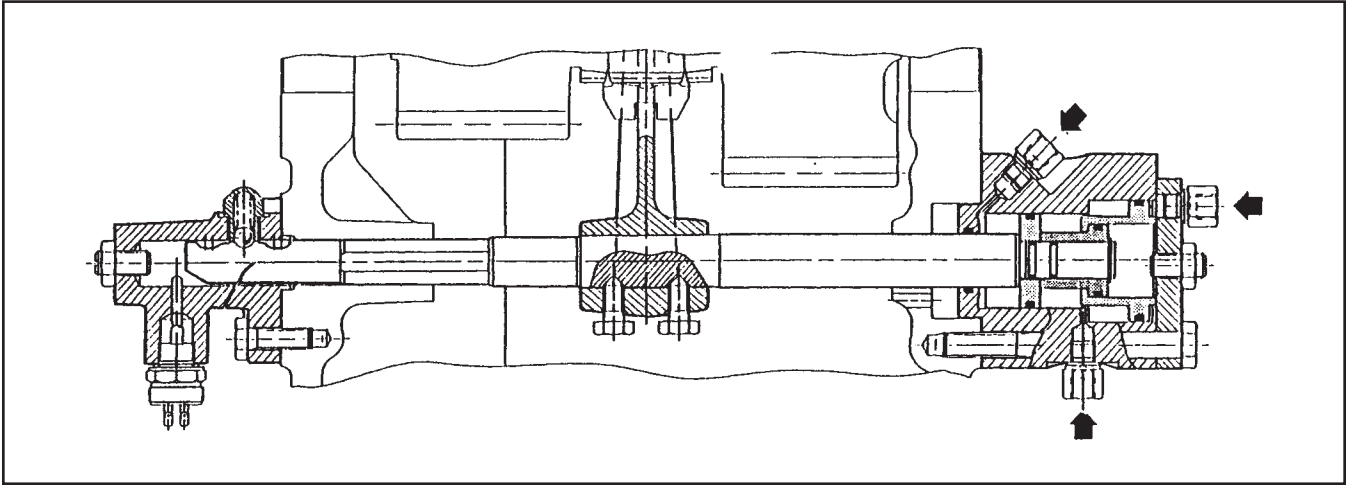

DESCRIPTION - Shift mechanism

Engagement of the front axle drive as well as the PTO is performed pneumatically (6.5 to 8 bar air pressure).
Disengaging is done by the return spring which is installed in the shifting cylinder.

Pneumatic Shifting:

High and Low

2/3 positions without return spring

MVG 750

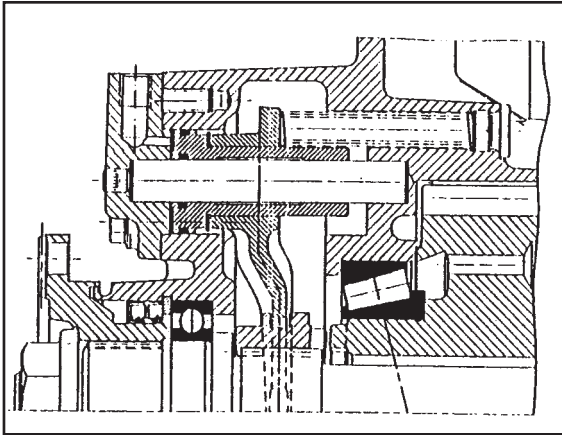

MVG 1200

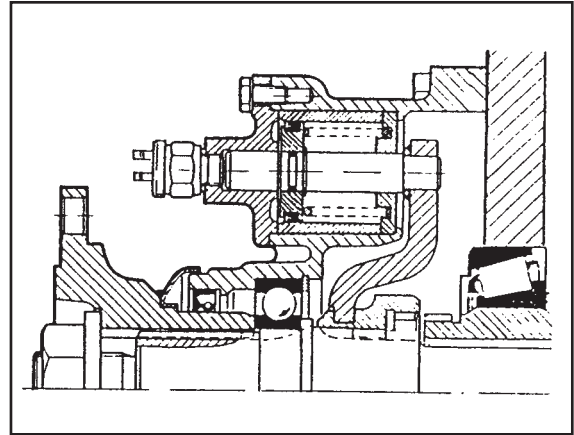

MVG 754

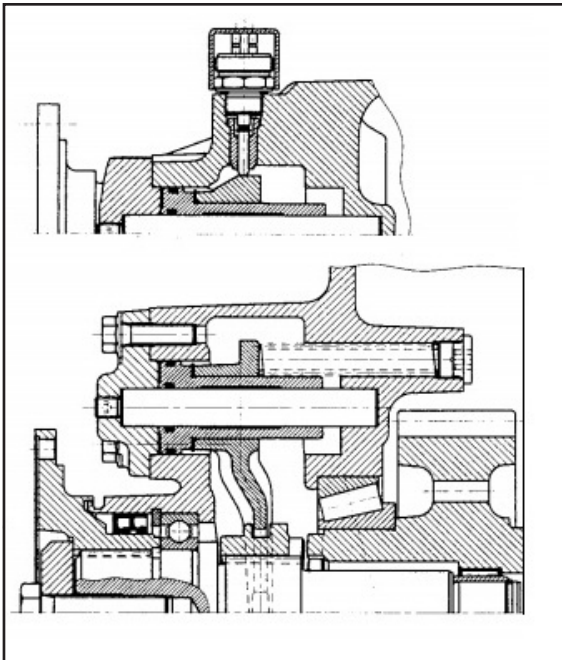

Pneumatic Shifting: Power Take Off (PTO)

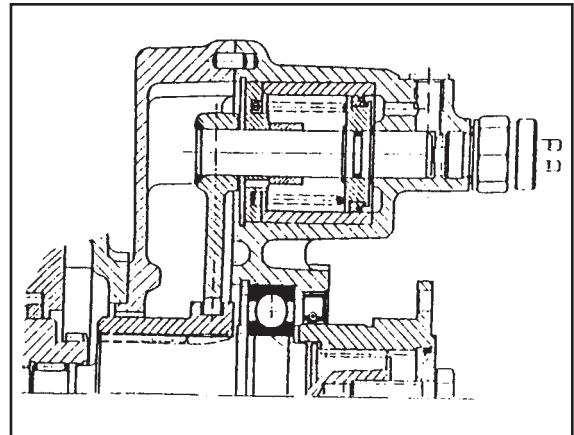

Magnetic drain plugs perform the vital function of trapping small metallic particles that circulate in the lubricant, through the gears and bearings, causing rapid wear and premature failure.

REFERENCE ONLY:

- A. Never add lubricant to axle or transfer case unless it is the same make and grade as that which is already in the axle or transfer case. If the same lubricant is not available, drain and refill.
- B. CHECKING LEVEL
Remove filler plug. Lubricant should be level with bottom of tapped filler hole.
- C. AIR VENTS
Check every 2,000 miles (3,200 km) – Clean in solvent.

SCHEDULED MAINTENANCE SERVICES

COMPONENT	(CODE)
Front Axle Differential Carrier	(1) (2) (4) (6)
Steering Axle Wheel Ends	(2) (5) (6)
Brake Lubrication	(2) (6)
Tie Rod Lubrication	(3) (6)
Drag Link Lubrication	(3) (6)
Drivelines Lubrication	(2) (3) (6)
Transfer Case Lubrication	(1) (2) (4) (6)
Wheel Bearing Lubrication	(5) (6)

(CODE)

1. Change after first 1,000 miles (1,600 km)
2. Check each 1,000 miles (1,600 km)
3. Lubricant every 2,000 miles (3,200 km)
4. Drain and refill every 10,000 miles (16,000 km)
5. Repack every 10,000 miles (16,000 km)
6. More frequent intervals may be required under adverse operating conditions.



LUBRICATION GUIDE:
TRANSFER CASE MODELS: MVG750, MVG754, MVG1200, MVG1600, MVG2000

SERVICE AND MAINTENANCE

OIL CHANGE AND OIL LEVEL CHECK

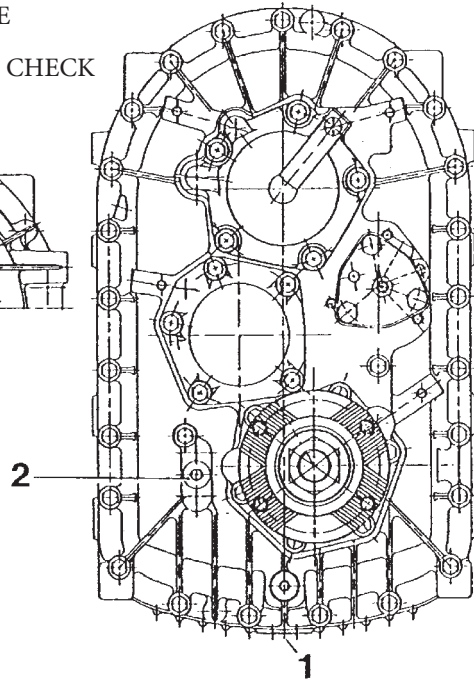
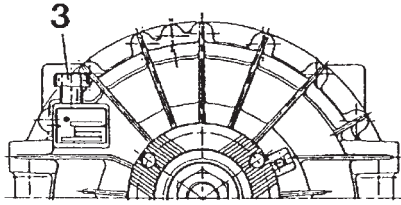

- 1 oil drain plug
- 2 level plug
- 3 breather

MVG750

- OIL CHANGE** (recommended in warm condition)
- drain gear oil at drain plug (1)
 - clean magnet of drain plug
 - mount drain plug with new seal
 - fill new gear oil at filling bore/level bore (2) until it flows over
 - mount level plug (2) with new seal
 - unscrew breather (3), clean it and mount it again

OIL LEVEL CHECK

- open oil filling/level plug (2)
- oil level must reach edge of level bore, if necessary top up
- mount level plug with new seal

without longitudinal differential
 approx. 6,4 l
 13.5 pts.

with longitudinal differential
 approx. 5,5 l
 11.6 pts.

ATTENTION: Assure correct oil level. Low level causes lack of lubrication and reduces durability. Too high level causes excessive splashing and leads to overheating of transfer case.

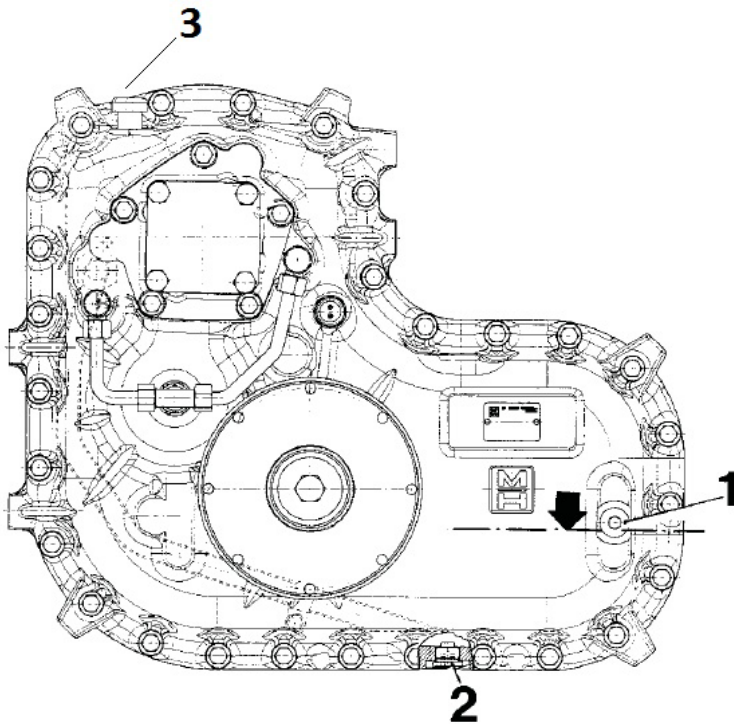

- 1 fill and level plug
- 2 drain plug
- 3 vent

MVG754

- OIL CHANGE** (recommended in warm condition)
- drain lube through bottom plug (2)
 - clean magnetic plug and replace
 - add lube from fill plug (1) until lube just starts to flow from port
 - replace plug and torque to ± 10 N·m

without longitudinal differential
 approx. 6,5 l
 18 pts.

ATTENTION: Assure correct oil level. Low level causes lack of lubrication and reduces durability. Too high level causes excessive splashing and leads to overheating of transfer case.



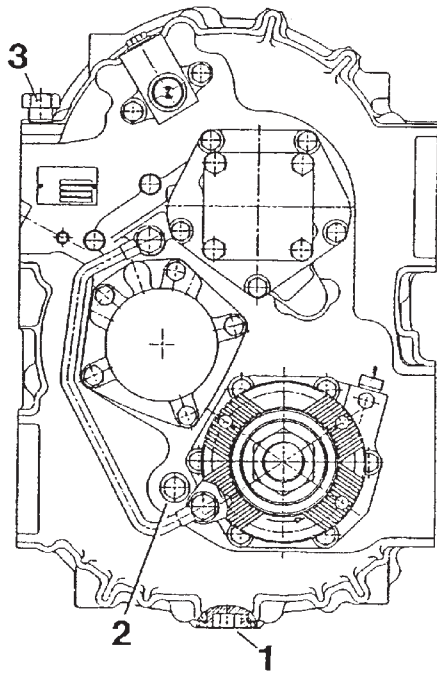

MVG1200

- OIL CHANGE (recommended in warm condition)
- drain gear oil at drain plug (1)
 - clean magnet of drain plug
 - mount drain plug with new seal
 - fill new gear oil at filling bore/level bore (2) until it flows over
 - mount level plug (2) with new seal
 - unscrew breather (3), clean it and mount it again

- OIL LEVEL CHECK
- open oil filling/level plug (2)
 - oil level must reach edge of level bore, if necessary top up
 - mount level plug with new seal

without longitudinal differential
approx. 4,6 l
9.7 pts.

with longitudinal differential
approx. 3,5 l
7.8 pts.

- 1 oil drain plug
- 2 level plug
- 3 breather

ATTENTION: Assure correct oil level. Low level causes lack of lubrication and reduces durability. Too high level causes excessive splashing and leads to overheating of transfer case.

MVG1600

- 1 Oil filling plug
- 2 Oil drain plug
- 3 Oil level plug
- 4 Breather

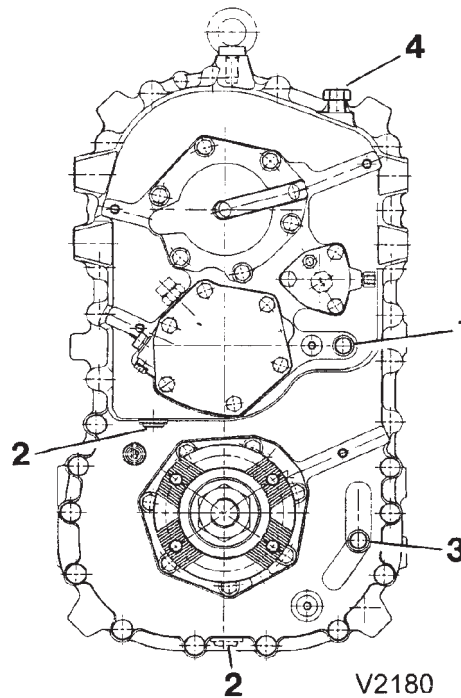

V2180

- Drain oil by unscrewing both oil drain plugs (2)
- Install oil drain plugs (2) with new seals
- Fill oil through oil filling bore (1) until it starts to overflow at oil level bore (3)
- After setting of correct oil quantity Install oil level plug (3) with new seal
- Clean and install breather (4)



MVG2000 (Long Drop)

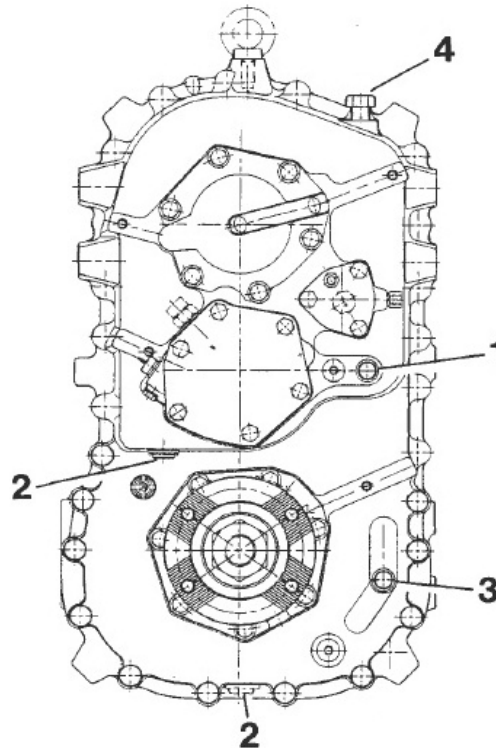

- 1 oil filling plug
- 2 oil drain plug
- 3 level plug
- 4 breather

- OIL CHANGE** (recommended in warm condition)
- drain gear oil at drain plug (2)
 - clean magnet of drain plug
 - mount drain plug with new seal
 - fill new gear oil at filling bore/level bore (1) until it flows over (3)
 - mount level plug (3) with new seal
 - unscrew breather (4), clean it and mount it again

- OIL LEVEL CHECK**
- open oil filling/level plug (3)
 - oil level must reach edge of level bore, if necessary top up
 - mount level plug with new seal

without longitudinal differential
approx. 7,1 l
15 pts.

with longitudinal differential
approx. 6,5 l
13.74 pts.

ATTENTION: Assure correct oil level. Low level causes lack of lubrication and reduces durability. Too high level causes excessive splashing and leads to overheating of transfer case.

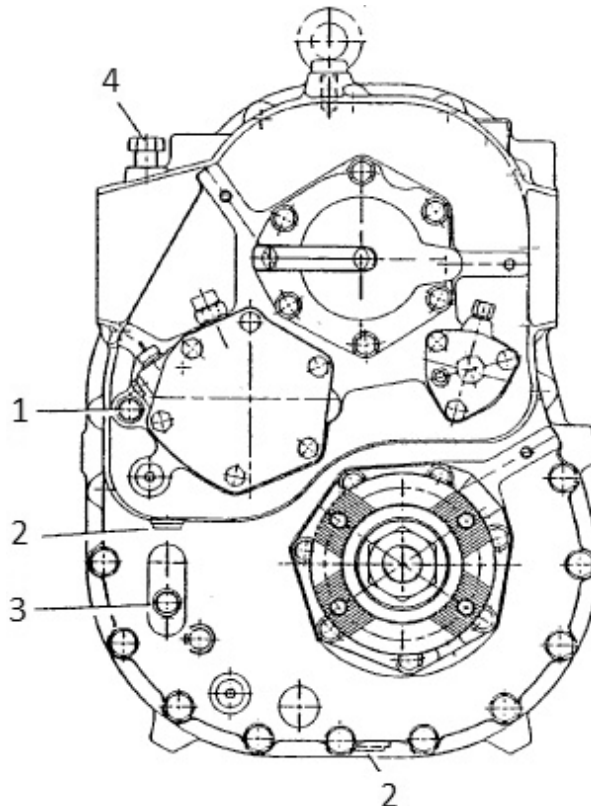

- 1 oil filling plug
- 2 oil drain plug
- 3 level plug
- 4 breather

MVG2000 (Short Drop)

- OIL CHANGE** (recommended in warm condition)
- drain gear oil at drain plug (1)
 - clean magnet of drain plug
 - mount drain plug with new seal
 - fill new gear oil at filling bore/level bore (2) until it flows over
 - mount level plug (2) with new seal
 - unscrew breather (3), clean it and mount it again

- OIL LEVEL CHECK**
- open oil filling/level plug (2)
 - oil level must reach edge of level bore, if necessary top up
 - mount level plug with new seal

without longitudinal differential
approx. 9,0 l
19 pts.

with longitudinal differential
approx. 8,4 l
17.75 pts.

ATTENTION: Assure correct oil level. Low level causes lack of lubrication and reduces durability. Too high level causes excessive splashing and leads to overheating of transfer case.



T SERIES TRANSFER CASES

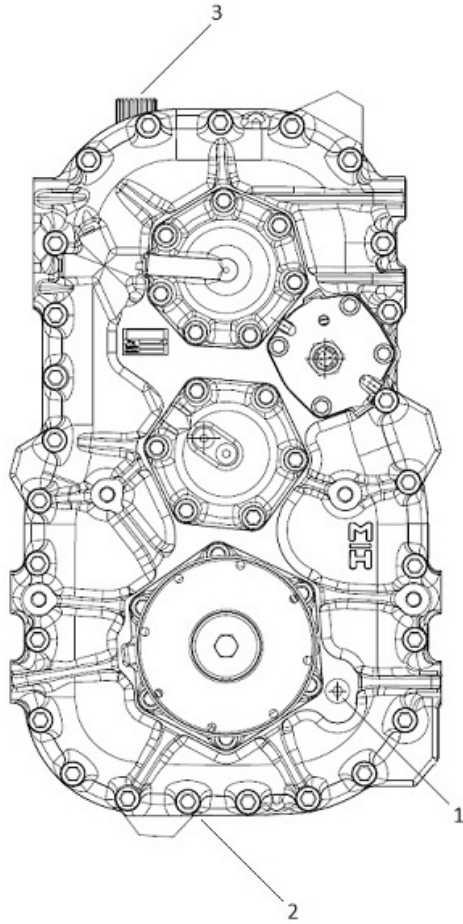

T30-420

DRAIN OIL IN WARM CONDITIONS.
DRAIN LUBE THROUGH BOTTOM PLUG (2).
CLEAN MAGNETIC PLUG AND REPLACE.
ADD LUBE THROUGH FILL PLUG (1) UNTIL
LUBE JUST STARTS TO FLOW FROM PORT.
REPLACE PLUG.

LUBE QTY: APPROX: 6.2L / 13.1 PINTS

- 1 - FILL AND LEVEL PLUG
- 2 - DRAIN PLUG
- 3 - VENT

T30: DO NOT operate with
unit in neutral, except for towing.
The lube pump drive is on idler shaft,
thus top shaft does not receive lube
in neutral position. The same applies
to 25 Series.

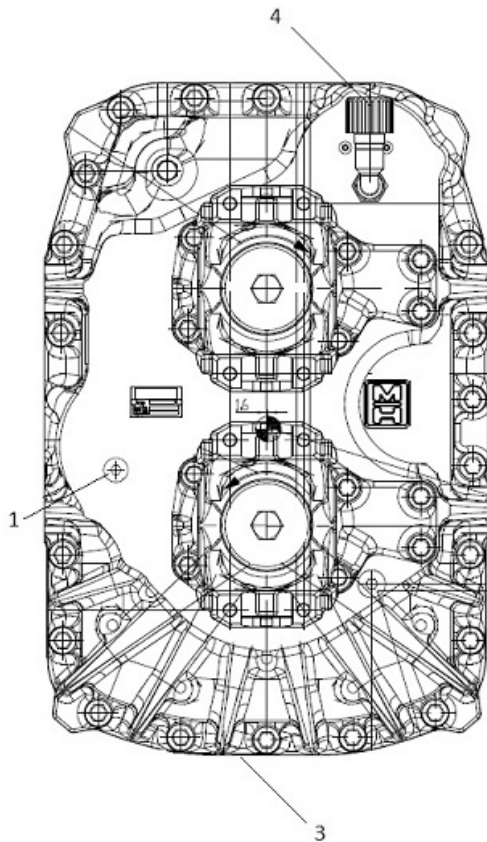

T 60

- 1 - FILL PLUG
- 2 - LEVEL PLUG
- 3 - DRAIN PLUG
- 4 - VENT

FILL FROM PLUG (1) UNTIL LUBE
JUST STARTS TO FLOW FROM LEVEL
PLUG (2).

T-60: Drive shaft must be
removed for towing.

Procedures for FAE and HI/LO
shifting the same as MVG series
units.



FRONT AXLE

CASTER



CASTER: Backward tilt of king pin at top. To cause front wheels to run straight normally, straighten up after turn, and give trailing action to wheels.

CAMBER

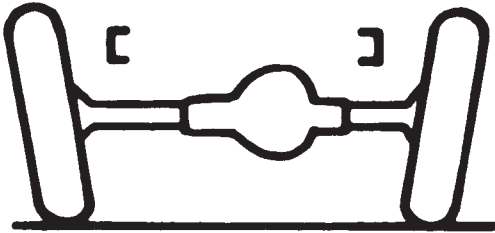

CAMBER: Outward tilt of front wheels at top. To bring road contact point of wheel more nearly under center of load. Important tire saving adjustment.

TOE IN

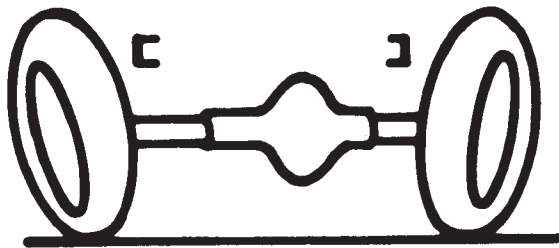

TOE-IN: Drawing together of front wheels at front at hub height. To prevent excessive tire wear.

KING PIN INCLINATION

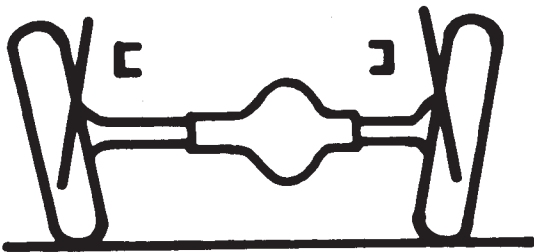

KING PIN INCLINATION: Inward tilt of king pin at top to compensate for shearing action on king pin which would result if wheels were left vertical and had no camber and no king pin inclination.

DRAG LINK & TIE ROD NOMENCLATURE:

The term DRAG LINK is the component that connects the Front Axle steering arm to the steering gear box.

The term TIE ROD is the component that connects the left and right front axle wheels.



ADJUSTMENTS

A. CASTER

A change in axle caster could indicate front axle housing distortion, which might be caused by a minor accident, or a permanent set in the front springs.

This is read by a protractor mounted on the pinion U-joint. Consult the respective axle specifications to determine the actual caster reading.

TO CORRECT:

If front springs are badly distorted, it is advisable to install new leaves or complete new springs.

It may only be necessary to install tapered shims between the front axle spring pads and springs. The position of the thick part of the shim will be determined by the direction in which the axle must be tilted in order to bring the caster angle to the correct specification.

B. CAMBER

Front wheel camber is controlled by the axle housings, and cannot be changed.

TO CORRECT:

Call the Factory. The application of heat will destroy the heat treatment and make the housing susceptible to distortion.

C. TOE-IN

Front wheel toe-in is controlled by the length of the tie rod.

For smooth operation and ease of steering at highway speeds, the axle has been adjusted such that the wheel mounting surfaces at the front are slightly closer together than on the rear side. This difference should measure $1/8'' + 1/16''$.

TO CORRECT:

The length of the tie rod is adjusted by rotating the threaded end (ends) through a complete turn.

Turning the tie-rod one way will slightly increase the toe-in, while rotating it the other way will slightly decrease it with each turn.

In the event the tie rod becomes bent, it should be replaced, as it will again bend easily even though straight-ened to its original form.

D. TIE ROD ENDS

Tie rod yoke pins should be adjusted to eliminate lost motion. Tie rod pins and bushings, or ball sockets, should be replaced if worn.

E. STEERING GEAR

The steering gear should be adjusted to eliminate excessive looseness. The standard original steering gear is used, therefore, the original service operation applies.

F. U-BOLT AND STUD NUTS

Front spring U-bolt nuts should be securely tightened. If the front axle continues to shift on the springs, it is an indication that the spring center bolts are sheared and they should be replaced.

G. WHEELS AND TIRES

Check wheels and tires for runout and balance.

See that tires are inflated to recommended pressure, in order to provide the SAME TIRE ROLLING RADIUS, FRONT AND REAR.



H. WHEEL BEARINGS

In order to ensure top performance long bearing life, the tapered-roller bearings must be properly preloaded upon assembly anytime the outer and assembly is disassembled. Proper adjustment is obtained by tightening the inner bearing nut, with the bearings in position, until the hub will no longer turn. Then back off the nut approximately 1/8 revolution, install retainer and outer nut, and lock in position. The hub should now turn freely with no perceivable end-play. Consult the specific axle maintenance manual for a more detailed procedure.

I. GENERAL INFORMATION

(1) Lubrication — Lubricate the front axle assembly in accordance with the Lubrication Chart of this manual. **DO NOT OVER LUBRICATE.** If the differential, universal joints, or hub bearings are over-lubricated, the lubricant will be pressurized past the oil seals and vents and may do damage by destroying the seal as well as entering the brakes.

(2) LOOSE ADJUSTMENTS— As soon as a looseness is noted in the hub bearings pivot pins, or other adjustable points, attention should be given to these items. Normal wear is slight but develops more rapidly as looseness occurs. If a unit is operated for a long length of time with a prevailing perceptible looseness, it will impose a pounding action on the parts involved. This may result in severe damage or destruction of parts and cause the necessity of replacement. This service repair can be avoided by preventive maintenance in eliminating the looseness as it develops, by performing the necessary adjustments.

TROUBLE SHOOTING

PROBLEM	POSSIBLE CAUSE
Transfer case or axle running "Hot"	Improper lubrication
Excessive driveline or gear noise	Driveline imbalance Improper lubrication Loose or worn parts
Steering instability (shimmy)	Wheels and/or tires out of balance Over or under inflated tires Worn or loose parts Improper lubrication Overload
Excessive or uneven tire wear	Wheels and/or tires out of balance Improper alignment Over or under inflated tires.



LUBRICATION GUIDE:
FRONT DRIVING STEER AXLES: MODELS: MT10/11, MT14/17, MT22/23

MODEL	MT10/11 AXLE	MT14/17 AXLE	MT22/23 AXLE
WHEEL ENDS		2.0 pints	2.0 pints
DIFFERENTIAL	17.0 pints	17.0 pints	17.0 pints

NOTE: All capacities approximate

LUBRICATION POINTS: (Fig. 1 and 2)

- 1 — oil level check & filter bore screw plug
- 2 — oil drain bore screw plug
- 3 — vent valve
- 4 — steering swivel bearings (bottom-top)
- 5 — slack adjuster
- 6 — brake camshaft bearings
- 7 — tie-rod ball joints

MT14, MT17, MT22, MT23

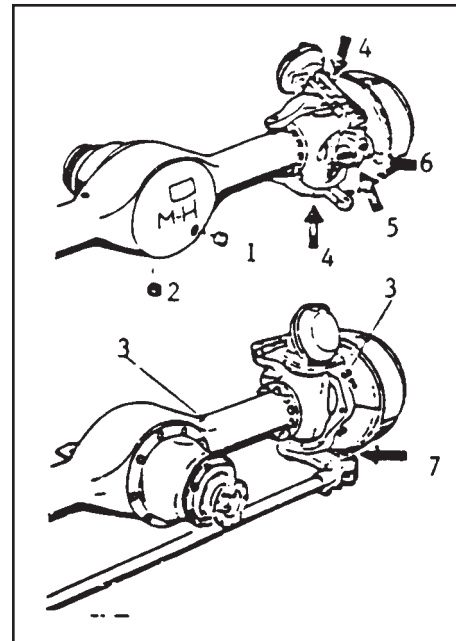
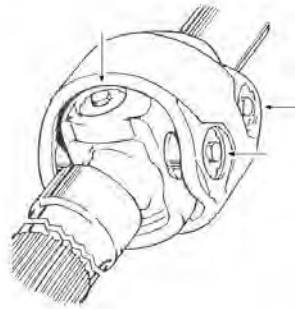

fig. 1

CARDAN-JOINT SERVICE

The Cardan-Joint caps are fitted with plugged threaded ports that are used for disassembly/assembly. While these ports will accept a standard zerk fitting, we recommend that only a needle attachments be used to flow lube into these joints. Adding lube under pressure may result in the failure of the cup seal.



MANUAL SLACK ADJUSTERS:

MT10, MT11

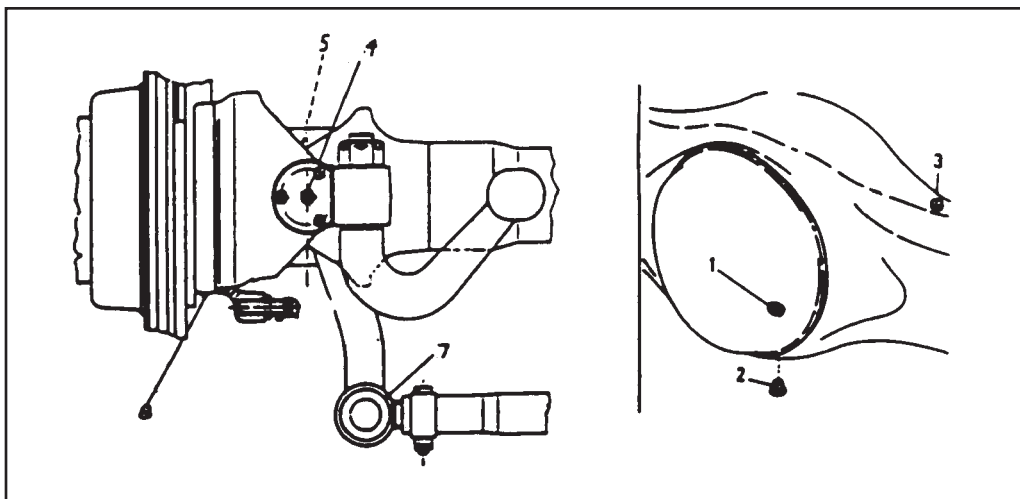
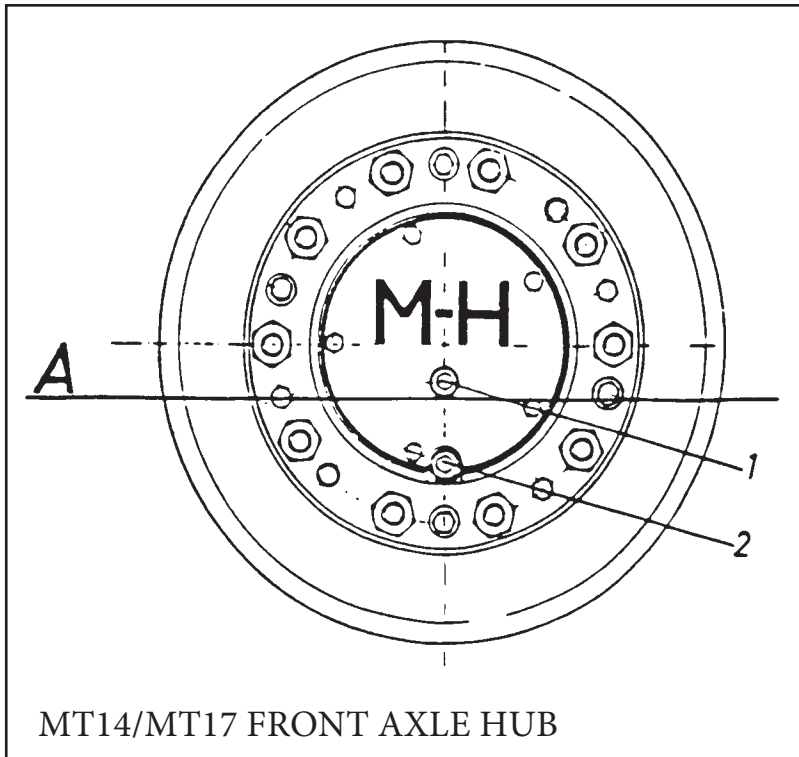

fig. 2



OIL LEVEL OF WHEEL HUBS: MT14, MT17, MT22, MT23



1 — Plug for OIL FILLING and inspection hole

2 — Plug for DRAIN hole

A — Line of OIL LEVEL

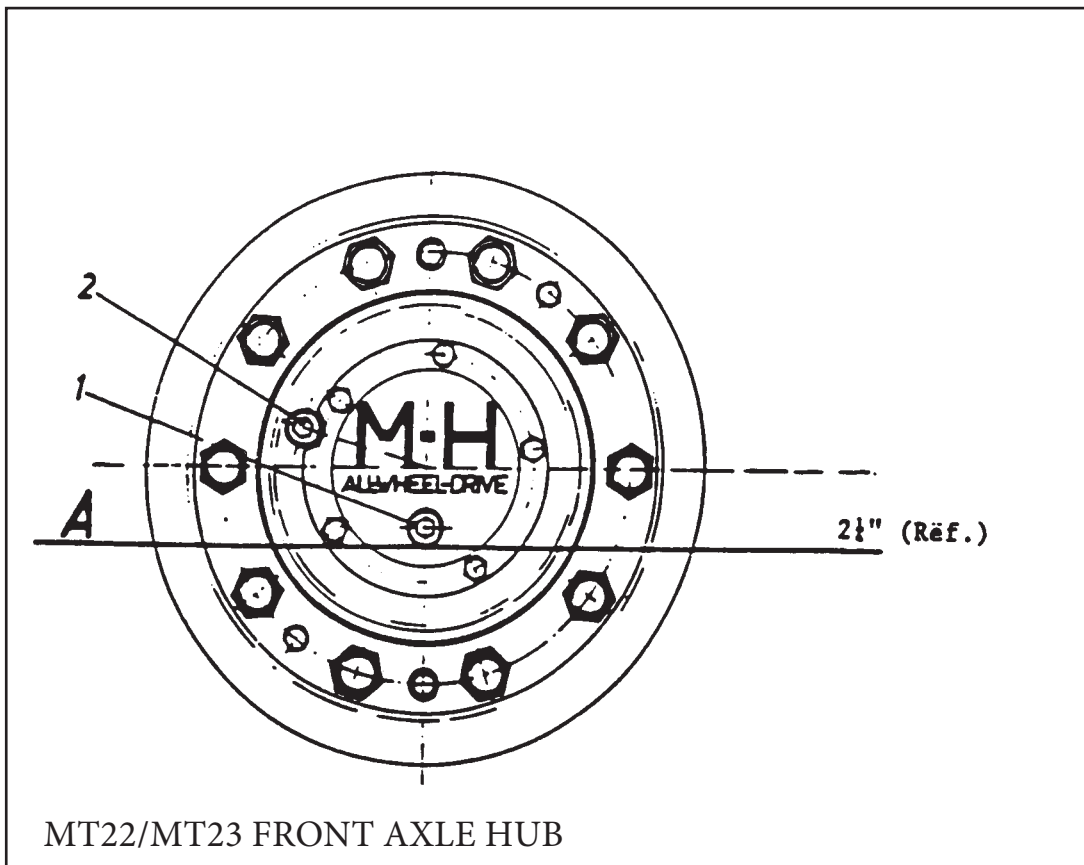

SERVICE AND MAINTENANCE RECOMMENDATIONS FOR SISU AXLES IN THE SPECIAL TRANSPORT APPLICATIONS

Axle types: Sisu Rigid Hub Reduction Drive Axles with S-Cam Drum Brakes

FIRST SERVICE AT 125 HOURS:

- Change the oil in the differential carrier and the hubs
- Check and adjust if necessary the wheel bearings
- Check the overall condition of the axle (possible oil leaks, etc.)

MAINTENANCE INTERVAL 250 HOURS:

- Check and adjust if necessary the wheel hub bearings

MAINTENANCE INTERVAL 500 HOURS IN ADDITION:

- Change the oil in the differential carrier and the hubs if no oil analysis based oil changing system in use
- Check the adjustment and the proper operation of the slack adjusters
- Check the brake lining thickness (if less than 6 mm, the linings have to be replaced)
- Check the oil level in the differential carrier and the hubs
- Check that the breather is working properly
- Check the overall condition of the axle (possible oil leaks, etc.)
- Inspect the condition of the planetary gears

MAINTENANCE INTERVAL 1000 HOURS IN ADDITION:

- Overhaul brakes per Brakes Workshop Manual. [Disassemble. Clean (wash) and degrease all moving parts (rollers and anchor bolts must be greased with heat resisting Molykote CU 7439 copper paste or equivalent). Check the bushings and seals for wear. Check the brake drums for heat cracks and wear, re-machining when necessary.]

MAINTENANCE INTERVAL 5000 HOURS IN ADDITION (THROUGH DRIVE AXLES ONLY):

- Remove the inter-axle differential and inspect and replace if necessary all excessively worn or damaged inter-axle differential parts.

GREASING:

- Grease all fittings according to the vehicle's standard schedule.
(Grease quality for grease lubrication: NLGI 2, Mobil Grease MP or comparable.)

Please refer to appropriate service manual for correct fill and drain locations.

Sisu Axle Oil Capacities (liters)

Axle	Carrier	Hubs Standard	Hubs Cooled	Axle Total		Note
				Hubs Standard	Hubs Cooled	
FSDP-10	12	1.2		13.2		
FSMP-10	17	1.2		18.2		
FRDP-10	12	1.2		13.2		
FRMP-10	17	1.2		18.2		
FSDP-14	18	2.8		20.8		
FSMP-14	24	2.8		26.8		
FSFP-14	22.5	2.8		25.3		
FSND-12		3.6		3.6		
FRDP-13/16	18	3	5	21	23	FuPro
FRMP-13/16	24	3	5	27	29	FuPro
FRDP-20	18		6		24	FuPro
FRMP-20	24		6		30	FuPro
FRFP-13/16	22.5	3	5	25.5	27.5	FuPro
FRDP-14	18	2.8		20.8		
FRMP-14	24	2.8		26.8		
FRFP-14	22.5	2.8		25.3		
SRDP-30-S	18	3	5	21	23	FuPro

NOTE: Capacities are based on installing angles of 3 degrees or less



BRAKE LEVER ADJUSTING: MT11, MT14, MT17, MT22, MT23 MODEL AXLES

- 1 — brake lever
- 2 — worm shaft
- 3 — cam shaft

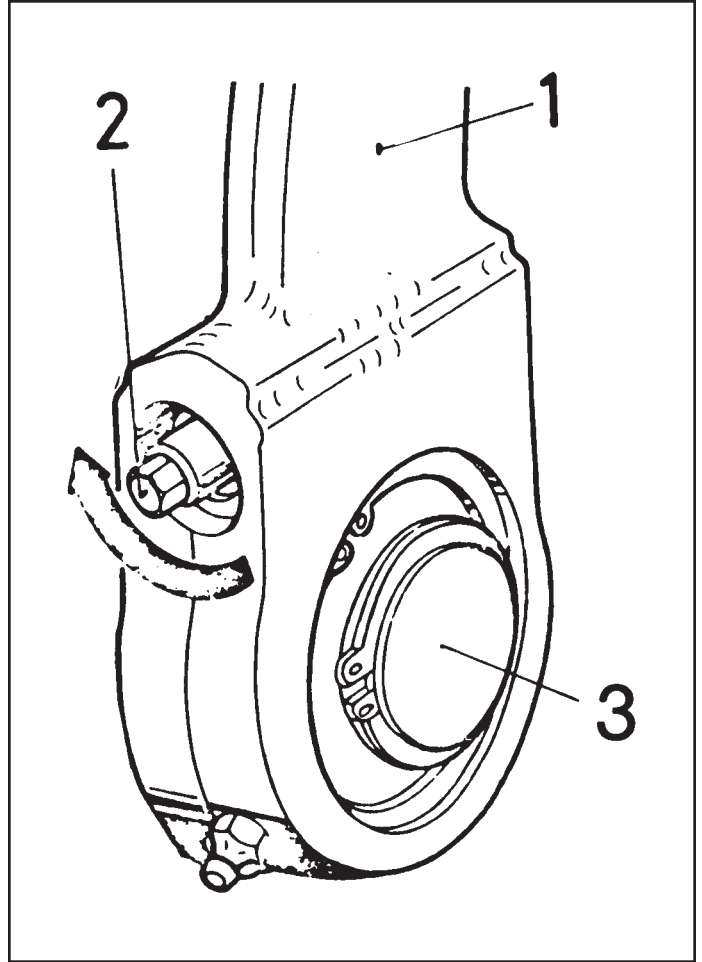

Adjustment of the front brake is performed by turning off the worm gears of the adjustable brake lever.

Using a wrench, turn the worm shaft until the brakes stop wheel rotation. Now back off the worm shaft until only a slight drag is felt turning the wheel by hand. The shoe clearance can be checked with a feeler gauge through an opening in the brake cover plate.



AUTOMATIC SLACK ADJUSTER

ITEMS:

- 1 — Adjusting plate
- 2 — Setscrew (hex. dist. 13)
- 3 — Setscrew (hex. dist. 10)
- 4 — Plastic protection cap
- 5 — Hex. adjusting ring (hex. dist. 32)
- 6 — Stop pin
- 7 — Plastic thread protector

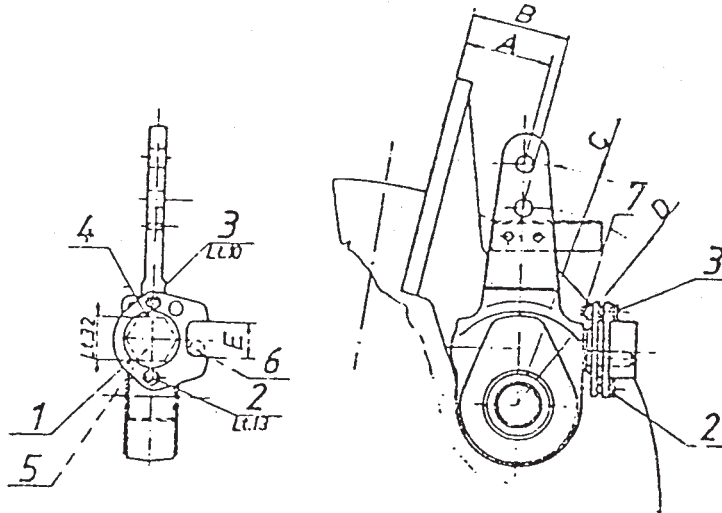

The slack adjuster requires no maintenance, since it is automatically readjusted according to brake lining wear.

When replacing the brake linings, or after repairing the axle, perform adjustment of the shoe clearance and automatic slack adjuster as follows:

ADJUSTMENT DATA:

A = Distance between the chamber holder plane and the brake lever bore.

B = Distance between the chamber holder plane and the brake lever bore.

C = Brake lever installation radius.

D = Brake lever installation radius.

a. Adjusting position of the brake lever and the shoe clearance:

- Remove setscrews (2,3).
- Take care of the plastic thread protector (7).
- Remove the adjusting plate (1) and the plastic protection cap (4).

By turning the hex adjusting ring (5) to proper direction, adjust for the specified distance between the seating surface and the brake lever bore. (Start adjustment from a distance greater than specified. If required, also adjust the push rod clevis.)

- After the above operation adjust the shoe clearance to 0.3 — 0.6 mm.



REPLACEMENT PARTS

When ordering replacement parts for MARMON-HERRINGTON ALL-WHEEL DRIVE conversions, the following information should be given:

1. FACTORY ORDER NUMBER (found on I.D. Plate on driver's door panel or small plate affixed to axle housing). This will be a six (6) digit number. (See illustrations this page.)
2. Component for which parts are required, i.e. front drive axle or transfer case.
3. Model of axle and/or transfer, i.e. MR-90, MR-226.

The information necessary for replacement parts and/or warranty claim procedures will be found on either plate design.

MARMON-HERRINGTON			
SALES ORDER	0000-00	TYPE	
S/N		RATIO	

WARRANTY CLAIM PROCEDURE

When ordering parts which you feel might be covered under warranty, advise the following information:

1. FACTORY ORDER NUMBER (found on I.D. Plate on driver's door panel or small plate affixed to axle housing). This will be a six (6) digit number. (See illustrations this page.)
2. Date unit was put into operation.
3. Mileage of unit at time of failure.
4. Nature of failure.

Upon receipt of the above, you will be advised as to how to proceed with the claim.

	
LOUISVILLE, KENTUCKY U.S.A.	
FACTORY ORDER NO.	0000-00
INSTALLED BY	
FRONT DRIVING AXLE	
MODEL	
CAPACITY	
SERIAL NO.	
RATIO	
TRANSFER CASE	
MODEL	
SERIAL NO.	



MARMON-HERRINGTON WARRANTY

This is to certify that we, Marmon-Herrington Company, Louisville, Kentucky, warrant each new chassis remanufactured, or assembly or part furnished for the remanufacture of a truck chassis against defects in material and workmanship under normal use and service. Marmon-Herrington's obligation under this warranty is limited to replacement of, at our factory, any part or parts thereof which shall, within one (1) year after delivery of such vehicle to the final user, but not later than eighteen (18) months after installation of the all-wheel drive conversion kit, or prior to the time when such vehicle has been operated twelve thousand (12,000) miles, whichever first occurs, be returned to us with transportation charges prepaid, and which our examination shall disclose to our satisfaction to have been thus defective.

Service parts are manufactured to the same standards as production installed parts. However, since the installation thereof, as well as the age and condition of the receiving vehicle are beyond the control of Marmon-Herrington, Service Parts are warranted for a period of ninety (90) days or five thousand (5,000) miles whichever first occurs. All other regular warranty conditions apply.

On vehicles operating OVERSEAS, the determination of defects will be made at Marmon-Herrington Company, Louisville, Kentucky, from complete information supplied in writing by overseas distributors or recognized acting distributors. Complete information is defined to mean: vehicle serial number, user's name, date of delivery, mileage at time of breakage, date of breakage, type of service, nature of break or fault, distributor's recommendation (for our guidance only), and any other pertinent information. After determination of our obligation, any parts to be replaced will be shipped to distributor or acting distributor in accordance with his instructions.

This warranty is in lieu of all other warranties expressed or implied and of all other obligations or liabilities incurred by Marmon-Herrington. Marmon-Herrington neither assumes nor authorizes any other person to assume any other liability in connection with this sale, including but not limited to indirect or consequential damages.

This warranty shall not apply to any vehicle which shall have been repaired or altered in any way so as in our judgment, to affect its stability or reliability, nor which has been subject to misuse, negligence, or accident, nor which shall have been operated at a speed exceeding the factory rated speed or loaded beyond the factory rated load capacity or operated in violation of Marmon-Herrington's instructions.

Marmon-Herrington makes no warranty whatever on components of the original manufacturer's chassis not related to the modification work. Also, no warranty is made on tires, rims, ignitions, or other parts usually warranted separately by their respective manufacturers.

The manufacturers reserve the right to make changes in design, and changes or improvements upon their product, without notice, and without incurring any obligation to install such changes or improvements upon their products theretofore manufactured.

This warranty shall become effective only when the Warranty Certificate has been returned to Marmon-Herrington and validated by same.



WARRANTY REPAIR AND CLAIM PROCEDURE

Initial Failure Reporting

1. Operator must call Marmon-Herrington Customer Service prior to performing any repairs and receive a Work Authorization Number to be eligible for reimbursement. The work authorization number does not guarantee payment but is an acknowledgement that the vehicle is within the warranty period in terms of date and mileage, and that a claim has been activated. It will be the responsibility of the operator to ensure that their repair facility is aware of and complies with the guidelines of this policy.
2. To expedite the authorization process, you will need the Sales Order Number or "S" number found on the front of this certificate. You will also need the Vehicle Identification Number or the last six digits of the "VIN", the date the vehicle was placed in service, and the current mileage. Please note the following:
 - This Warranty Registration should have been submitted at the time of delivery. If our records do not include a warranty registration, you must complete one before any authorization for repair can be issued. We will make them available by mail or fax upon request.
3. Marmon-Herrington will pre-approve .5 hours diagnosis/inspection time prior to your call for repair authorization. If the diagnosis/inspection complaint does not reveal a warrantable failure, or result in a warrantable repair, the customer will be responsible for all charges including diagnosis/inspection time.
4. The Operators Manual contains information covering proper equipment use and maintenance schedules. Operators must adhere to these guidelines to be eligible for reimbursement, and service records must be provided upon request.

Pre-Repair Requirements

1. Authorization for repairs will require a written estimate/repair order of costs after determination that a warrantable condition is found to exist.
2. Estimates must contain the following information:
 - A list of all parts necessary for specific job and if applicable, all parts that will be invoiced back to Marmon-Herrington.
 - The cost of disassembly, inspection and diagnosis of any portion of the vehicle to determine extent of repairs needed.
 - Current labor costs, reflecting both hourly rate and number of hours to effect repairs must be listed.
 - Miscellaneous charges such as "shop supplies" must be defined. Actual dollar amounts must be listed, as percentages will not be accepted.
 - Sublet repairs must also be defined and included in the estimate at their actual dollar amount.
 - NOTE: If it becomes necessary to exceed the original estimate in terms of parts or labor, the repair facility must call Marmon-Herrington Customer Service for additional authorization.
3. Only the use of Marmon-Herrington supplied parts will constitute reimbursement unless prior approval has been obtained.

Parts Ordering

1. While Marmon-Herrington operates a full service Parts Department, replacement parts needed to effect Warranty repairs must be acquired through Customer Service to be eligible for reimbursement.

Post Repair requirements.

1. The final invoice or work order must include the following:
 - Customer's name, address, and phone number.
 - The Vehicle Identification number.
 - The Sales Order Number or "S" number, which the customer can provide or can be located on the ID tag, fixed to the transfer case or axle.
 - The Axle or Transfer Case Model and Serial Number, also located on the ID tag.
 - Mileage IN / Mileage Out.
 - The Cause and Correction of the repair including detailed description of repairs and parts replaced.
 - The date the repair order was open and the date the repairs were completed.
 - The Work Authorization Number obtained from Customer Service.

Notes to Repair Facilities

1. Miscellaneous charges such as "shop supplies" must be listed as separate line items and shown on the final invoice as stated in "Pre-Repair Requirements". Invoices for sublet repairs must be made available upon request.
2. All repairs must comply with any or all state and DOT requirements.
3. Downtime of vehicle and incurred costs associated due to the delay of parts shipments or any other condition beyond our control is not reimbursable and should not be listed on the invoice.
4. All failed parts that are required to be returned to Marmon-Herrington must be received before payment will be made. The Return Authorization will be sent with the replacement parts when shipped from Marmon-Herrington.
5. All Claims must be submitted within 60 days of completion of repairs to be eligible for reimbursement.

For Work Authorization call: 800.227.0727 ext. 282

To Submit Claims by Fax: 502.253.0317

Submit Claims by Mail to: Marmon-Herrington Company

Customer Service Department
13001 Magisterial Drive
Louisville, KY 40223



NOTES



NOTES





Marmon-Herrington

13001 Magisterial Drive • Louisville, KY 40223
(502) 253-0277 • (800) 227-0727 • Fax (502) 253-0317
E-mail: info@marmon-herrington.com

